

# MERCURY METALS

## GENERAL NOTES for STANDING SEAM ROOF SYSTEMS

IMPERIAL - L.S.D.

Page 1 of 2

### DESIGN CRITERIA:

The properties listed in the following tables are based on one foot panel width. The properties of the steel profiles have been computed in accordance with CSA - S136-94 for limit states design.

### Cs COEFFICIENT OF STRESS:

To determine the maximum uniform factored load, governed by design stress, and not covered by the load tables, proceed as follows;

a) Simple Span:

$$\frac{C_s (\text{mid-span})}{(\text{span in feet})^2} \quad \text{psf}$$

b) Double Span: use the lessor of the following;

i)  $\frac{C_s (\text{support})}{(\text{span in feet})^2} \quad \text{psf}$

ii)  $\frac{C_s (\text{mid-span})}{(\text{span in feet})^2} \times 1.77 \quad \text{psf}$

c) Triple Span: use the lessor of the following;

i)  $\frac{C_s (\text{support})}{(\text{span in feet})^2} \times 1.25 \quad \text{psf}$

ii)  $\frac{C_s (\text{mid-span})}{(\text{span in feet})^2} \times 1.56 \quad \text{psf}$

**To determine the maximum specified uniform loads, as listed in the load tables, divide the results of the equations by 1.5.**

The loads determined by these formulas are for positive exterior loading on the exterior sheet in the normal position. For negative exterior loading on the exterior sheet in the normal position, or positive exterior loading on the inverted position; interchange the mid-span properties with the support properties.

### COEFFICIENT OF DEFLECTION:

To determine the maximum load governed by deflection limitations, and not covered by the load tables, proceed as follows:

a) Simple Span:

$$\frac{C_d}{(\text{span in feet})^3} \quad \text{psf}$$

b) Double Span:

$$\frac{C_d}{(\text{span in feet})^3} \times 2.4 \quad \text{psf}$$

c) Triple Span:

$$\frac{C_d}{(\text{span in feet})^3} \times 1.89 \quad \text{psf}$$

# MERCURY METAL

## GENERAL NOTES for STANDING SEAM ROOF SYSTEMS

IMPERIAL - L.S.D.

Page 2 of 2

The normal allowable deflections are as follows:

Standing Seam Roof:  $L / 180$

### WEB CRIPPLING:

Reactions at exterior and/or interior supports shall be equal or less than the factored bearing resistance shown on each load table. To determine the maximum uniform factored load, governed by web crippling, and not covered by the load tables, proceed as follows;

Exterior bearing:  $2 \times \frac{\text{EXT Bearing Resistance}}{(\text{span in feet})}$

Interior bearing:  $\frac{\text{INT Bearing Resistance}}{(\text{span in feet})}$

**To determine the maximum specified uniform loads, as listed in the load tables, divide the results of the equations by 1.5.**

### SPAN TABLE UNITS AND USE:

- a) The allowable spans shown in the load tables are in feet.
- b) The "A" column provides the allowable specified load capacity based on strength.
- c) The " B " column provides the allowable specified load capacity based on serviceability based on deflection requirements shown on each load table sheet.
- d) The table lists the lower value of bending capacity or web bearing resistance. The load is expressed in *italics* when bearing capacity governs.
- e) The loads shown in the tables are specified loads and have not been factored. Strength capacity in column "A" should be checked against the following formula:

$$\text{Specified Load in Table} > / = [\text{Specified Live Load}] + [0.833 \times \text{Specified Dead Load}]$$

- f) The load tables are based on the material grades and strengths shown on each load table.
- g) The minimum recommended roof slope for Standing Seam Roof Systems is 1 in 48. The Standing Seam Roof was developed for low slope roofs, however, due to their popularity these roofs are used in steeper roof applications where shear loads must be examined
- h) In addition to normal gravity loads, significant negative or uplift wind pressures and sliding shear forces can be applied to the roof system. The roof field and sidelaps must be adequately fastened to prevent failure due to uplift and shear forces. Resistance to these forces will depend on the following factors.
  - 1) Regional wind forces.
  - 2) Roof shape and slope angles.
  - 3) Cladding profile, gauge, and subgirt system ( if applicable )
  - 4) Type of roof system clip and spacing.
  - 5) The nature ( wood, steel, plywood, concrete ) and spacing of the underlying substructure.

It is important that the design of the substructure has taken in consideration the gravity, uplift and shear forces that will be applied from the exterior roof system and that adequate fastening of the substructure to the primary structural framing has been reviewed.

For assistance contact your Mercury Metals representative.

09/98

# MERCURY METALS

## GENERAL NOTES for STANDING SEAM ROOF SYSTEMS

METRIC - L.S.D.

Page 1 of 2

### DESIGN CRITERIA:

The properties listed in the following tables are based on one meter panel width. The properties of the steel profiles have been computed in accordance with CSA - S136-94 for limit states design.

### Cs COEFFICIENT OF STRESS:

To determine the maximum uniform factored load, governed by design stress, and not covered by the load tables, proceed as follows;

a) Simple Span:

$$\frac{Cs \text{ (mid-span)}}{(\text{span in meters})^2} \quad \text{kPa}$$

b) Double Span: use the lessor of the following;

i)  $\frac{Cs \text{ (support)}}{(\text{span in meters})^2} \quad \text{kPa}$

ii)  $\frac{Cs \text{ (mid-span)}}{(\text{span in meters})^2} \times 1.77 \quad \text{kPa}$

c) Triple Span: use the lessor of the following;

i)  $\frac{Cs \text{ (support)}}{(\text{span in meters})^2} \times 1.25 \quad \text{kPa}$

ii)  $\frac{Cs \text{ (mid-span)}}{(\text{span in meters})^2} \times 1.56 \quad \text{kPa}$

**To determine the maximum specified uniform loads, as listed in the load tables, divide the results of the equations by 1.5.**

The loads determined by these formulas are for positive exterior loading on the exterior sheet in the normal position. For negative exterior loading on the exterior sheet in the normal position, or positive exterior loading on the inverted position; interchange the mid-span properties with the support properties.

### COEFFICIENT OF DEFLECTION:

To determine the maximum load governed by deflection limitations, and not covered by the load tables, proceed as follows:

a) Simple Span:

$$\frac{Cd}{(\text{span in meters})^3} \quad \text{kPa}$$

b) Double Span:

$$\frac{Cd}{(\text{span in meters})^3} \times 2.4 \quad \text{kPa}$$

c) Triple Span:

$$\frac{Cd}{(\text{span in meters})^3} \times 1.89 \quad \text{kPa}$$

# MERCURY METALS

## GENERAL NOTES for STANDING SEAM ROOF SYSTEMS

METRIC - L.S.D.

Page 2 of 2

The normal allowable deflections are as follows:

Standing Seam Roof:  $L / 180$

### WEB CRIPPLING:

Reactions at exterior and/or interior supports shall be equal or less than the factored bearing resistance shown on each load table. To determine the maximum uniform factored load, governed by web crippling, and not covered by the load tables, proceed as follows;

Exterior bearing:  $2 \times \frac{\text{EXT Bearing Resistance}}{(\text{span in meters})}$

Interior bearing:  $\frac{\text{INT Bearing Resistance}}{(\text{span in meters})}$

**To determine the maximum specified uniform loads, as listed in the load tables, divide the results of the equations by 1.5.**

### SPAN TABLE UNITS AND USE:

- a) The allowable spans shown in the load tables are in meters.
- b) The "A" column provides the allowable specified load capacity based on strength.
- c) The " B " column provides the allowable specified load capacity based on serviceability based on deflection requirements shown on each load table sheet.
- d) The table lists the lower value of bending capacity or web bearing resistance. The load is expressed in *Italics* when bearing capacity governs.
- e) The loads shown in the tables are specified loads and have not been factored. Strength capacity in column "A" should be checked against the following formula:

$$\text{Specified Load in Table} > / = [\text{Specified Live Load}] + [0.833 \times \text{Specified Dead Load}]$$

- f) The load tables are based on the material grades and strengths shown on each load table.
- g) The minimum recommended roof slope for Standing Seam Roof Systems is 1 in 48. The Standing Seam Roof was developed for low slope roofs, however, due to their popularity these roofs are used in steeper roof applications where shear loads must be examined
- h) In addition to normal gravity loads, significant negative or uplift wind pressures and sliding shear forces can be applied to the roof system. The roof field and sidelaps must be adequately fastened to prevent failure due to uplift and shear forces. Resistance to these forces will depend on the following factors.
  - 1) Regional wind forces.
  - 2) Roof shape and slope angles.
  - 3) Cladding profile, gauge, and subgirt system ( if applicable )
  - 4) Type of roof system clip and spacing.
  - 5) The nature ( wood, steel, plywood, concrete ) and spacing of the underlying substructure.

It is important that the design of the substructure has taken in consideration the gravity, uplift and shear forces that will be applied from the exterior roof system and that adequate fastening of the substructure to the primary structural framing has been reviewed.

For assistance contact your Mercury Metals representative.

09/98

# MERCURY METALS LTD.

Imperial - L.S.D. S136-94

Mercury SNAP-RIB

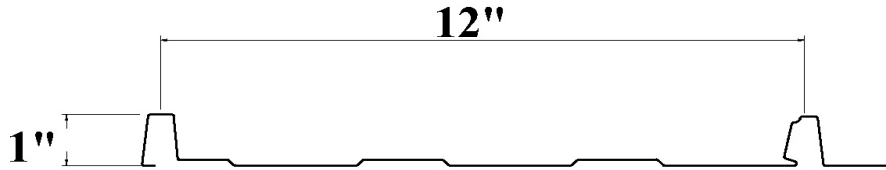

## Properties for Mercury SNAP-RIB

( Per foot width)

Gauge Number	Base Steel Nominal Thickness	Weight	Overall Depth	MID - SPAN					SUPPORT					Coeff. of Deflect.	Bearing Resist. 2"	
				Section Modulus		Coeff. of Stress	Moment of Inertia		Section Modulus		Coeff. of Stress	Moment of Inertia			L / 180	EXT
	Inches	PSF	Inches	Sm	In3	Csm	Im	In4	Ss	In3	Css	Is	In4			
26	0.018	1.102	1.023	0.0352		705	0.0292		0.0341		683	0.0157		2547	0.19	0.35
24	0.024	1.470	1.023	0.0469		938	0.0360		0.0460		920	0.0224		3375	0.31	0.64

## Specified Load Tables - psf

Span Ft.	ONE SPAN								TWO EQUAL SPANS								THREE EQUAL SPANS										
			0.018		0.024						0.018		0.024						0.018		0.024						
	A	B	A	B	A	B	A	B	A	B	A	B	A	B	A	B	A	B	A	B	A	B	A	B	A	B	
1.0			248	*	409	*					235	*	409	*						235	*	409	*				
1.5			165	*	273	*					157	*	273	*						157	*	273	*				
2.0			117	*	156	*					114	*	153	*						118	*	192	*				
2.5			75	*	100	*					73	*	98	*						91	*	123	*				
3.0			52	*	70	*					51	*	68	*						63	*	85	*				
3.5			38	*	51	*					37	*	50	*						46	*	63	*				
4.0			29	27	39	35					28	*	38	*						36	*	48	*				
4.5			23	19	31	25					22	*	30	*						28	*	38	*				
5.0			19	14	25	18					18	*	25	*						23	*	31	*				
5.5			16	10	21	14					15	*	20	*						19	19	25	*				
6.0			13	8	17	10					13	*	17	*						16	15	21	20				
6.5			11	6	15	8					11	*	15	*						13	12	18	15				

### Mercury SNAP-RIB Load Table Notes

- 1) Column 'A' - Loads based on stress. Column 'B' - Loads based on L / 180 deflection. ( \* ) denotes stress governs.
- 2) Table lists lower value of bending or bearing resistance. *Italic* denotes web crippling governs
- 3) For deflection loads other than L / 180 multiply column 'B' by the following factors:

DEFLECTION	MULTIPLIER
L / 90	2
L / 240	0.75
L / 360	0.5

- 4) Load tables based on use of A653 Structural Quality Steel Sheet Grade 33 ( maximum stress 29.7 Ksi ).

01/02

# MERCURY METALS

Metric - L.S.D. S136-94

Mercury SNAP-RIB

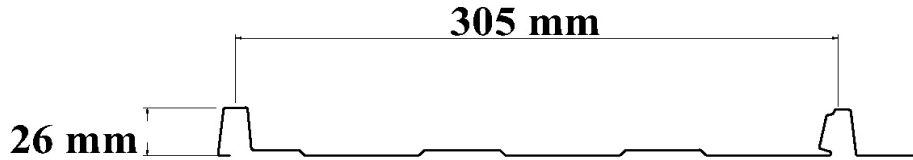

## Properties for Mercury SNAP-RIB

( Per meter width )

Gauge Number	Base Steel Nominal Thickness	Weight	Overall Depth	MID - SPAN					SUPPORT					Coeff. of Deflect.	Bearing Resist.		
				Section Modulus		Coeff. of Stress	Moment of Inertia		Section Modulus		Coeff. of Stress	Moment of Inertia			for 50 mm		
	mm	Kpa	mm	Sm	mm <sup>3</sup>	Csm	Im	mm <sup>4</sup>	Ss	mm <sup>3</sup>	Css	Is	mm <sup>4</sup>	L/180	kN / M	EXT	INT
				x10 <sup>3</sup>			x10 <sup>3</sup>	x10 <sup>3</sup>		x10 <sup>3</sup>		x10 <sup>3</sup>					
26	0.45	0.0527	26	1.886	3.1234	39.7	1.8280	3.0276	20.2	3.440	2.74	5.14					
24	0.61	0.0703	26	2.511	4.1583	52.6	2.4620	4.0768	28.7	4.559	4.45	9.29					

## Specified Load Tables - Kpa ( Kn/m<sup>2</sup> )

Span M.	ONE SPAN								TWO EQUAL SPANS								THREE EQUAL SPANS							
	0.46		0.61		0.46		0.61		0.46		0.61		0.46		0.61		0.46		0.61					
	A	B	A	B	A	B	A	B	A	B	A	B	A	B	A	B	A	B	A	B				
0.4		9.1	*	15	*			8.6	*	15	*			8.6	*	15	*							
0.5		7.3	*	11	*			6.9	*	10.9	*			6.9	*	12	*							
0.6		5.8	*	7.7	*			5.6	*	7.5	*			5.7	*	9.4	*							
0.7		4.2	*	5.7	*			4.1	*	5.5	*			4.9	*	6.9	*							
0.8		3.3	*	4.3	*			3.2	*	4.2	*			3.9	*	5.3	*							
0.9		2.6	*	3.4	*			2.5	*	3.4	*			3.1	*	4.2	*							
1.0		2.1	*	2.8	*			2.0	*	2.7	*			2.5	*	3.4	*							
1.2		1.4	1.3	1.9	1.8			1.4	*	1.9	*			1.8	*	2.4	*							
1.4		1.1	0.8	1.4	1.1			1.0	*	1.4	*			1.3	*	1.7	*							
1.6		0.8	0.6	1.1	0.7			0.8	*	1.1	*			1.0	*	1.3	*							
1.8		0.6	0.4	0.9	0.5			0.6	*	0.8	*			0.8	0.7	1.0	1.0							
2.0		0.5	0.3	0.7	0.4			0.5	*	0.7	*			0.6	0.5	0.8	0.7							

### Mercury SNAP-RIB Load Table Notes

- 1) Column 'A' - Loads based on stress. Column 'B' - Loads based on L / 180 deflection. ( \* ) denotes stress governs.
- 2) Table lists lower value of bending or bearing resistance. *Italic* denotes web crippling governs.
- 3) For deflection loads other than L / 180 multiply column 'B' by the following factors:

DEFLECTION	MULTIPLIER
L / 90	2
L / 240	0.75
L / 360	0.5

- 4) Load tables based on use of A653M Structural Quality Steel Sheet Grade 230 ( maximum stress 207 Mpa ).

# MERCURY METALS

Imperial - L.S.D. S136-94

## Mercury SNAP-RIB II

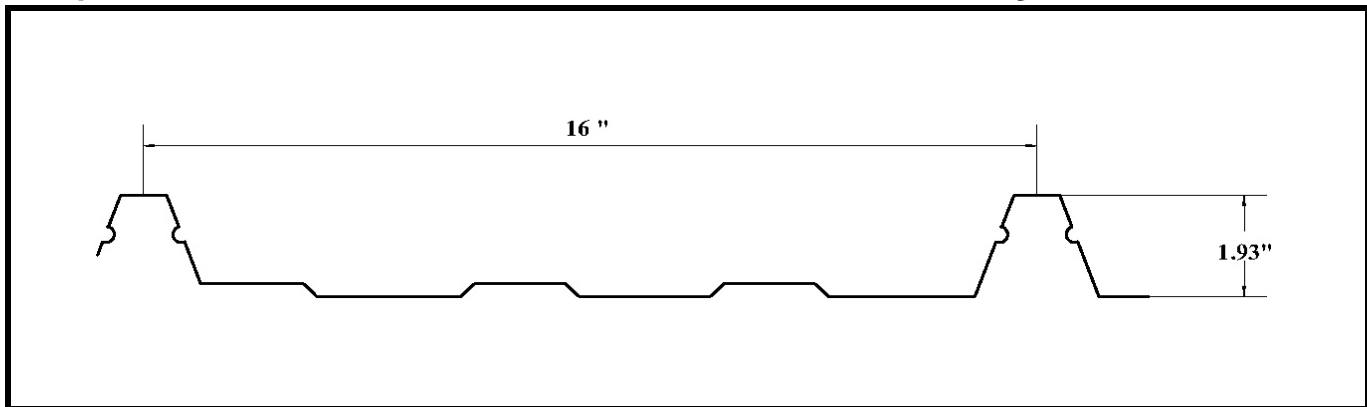

### Properties for Mercury SNAP-RIB II

( Per foot width)

Gauge Number	Base Steel Nominal Thickness	Weight	Overall Depth	MID - SPAN					SUPPORT					Coeff. of Deflect.	Bearing Resist. 2"	
				Section Modulus		Coeff. of Stress	Moment of Inertia		Section Modulus		Coeff. of Stress	Moment of Inertia			L / 180	EXT
	Inches	PSF	Inches	Sm	In3	Csm	Im	In4	Ss	In3	Css	Is	In4	L / 180	EXT	INT
26	0.018	1.103	1.91	0.1127		2232	0.1498		0.0525		1040	0.0584		13065	0.13	0.19
24	0.024	1.470	1.91	0.1526		3022	0.2022		0.0772		1529	0.0840		17617	0.21	0.36
22	0.030	1.836	1.91	0.1923		3808	0.2544		0.1122		2081	0.1051		22187	0.31	0.59

### Specified Load Tables - psf

Span Ft.	ONE SPAN								TWO EQUAL SPANS								THREE EQUAL SPANS							
	0.018		0.024		0.030				0.018		0.024		0.030				0.018		0.024		0.030			
	A	B	A	B	A	B	A	B	A	B	A	B	A	B	A	B	A	B	A	B	A	B	A	B
2.0	85	*	141	*	208	*			63	*	121	*	198	*			63	*	121	*	198	*		
2.5	68	*	113	*	166	*			50	*	97	*	158	*			50	*	97	*	158	*		
3.0	56	*	94	*	139	*			42	*	80	*	132	*			42	*	80	*	132	*		
3.5	48	*	80	*	119	*			36	*	69	*	113	*			36	*	69	*	113	*		
4.0	42	*	70	*	104	*			31	*	60	*	87	*			31	*	60	*	99	*		
4.5	38	*	63	*	92	*			28	*	50	*	69	*			28	*	54	*	86	*		
5.0	34	*	56	*	83	*			25	*	41	*	55	*			25	*	48	*	69	*		
5.5	31	*	51	*	76	*			23	*	34	*	46	*			23	*	42	*	57	*		
6.0	28	*	47	*	69	*			19	*	28	*	39	*			21	*	35	*	48	*		
6.5	26	*	43	*	60	54			16	*	24	*	33	*			19	*	30	*	41	*		
7.0	24	*	40	34	52	43			14	*	21	*	28	*			18	*	26	*	35	*		
7.5	23	21	36	28	45	35			12	17	18	32	25	53			15	17	23	32	31	53		

#### Mercury SNAP-RIB II Load Table Notes

- 1) Column 'A' - Loads based on stress. Column 'B' - Loads based on L / 180 deflection. ( \* ) denotes stress governs.
- 2) Table lists lower value of bending or bearing resistance. *Italic* denotes web crippling governs
- 3) For deflection loads other than L / 180 multiply column 'B' by the following factors:

DEFLECTION	MULTIPLIER
L / 90	2
L / 240	0.75
L / 360	0.5

- 4) Load tables based on use of A653 Structural Quality Steel Sheet Grade 33 ( maximum stress 29.7 Ksi ).

01/02

# MERCURY METALS

Metric - L.S.D. S136-94

Mercury SNAP-RIB II

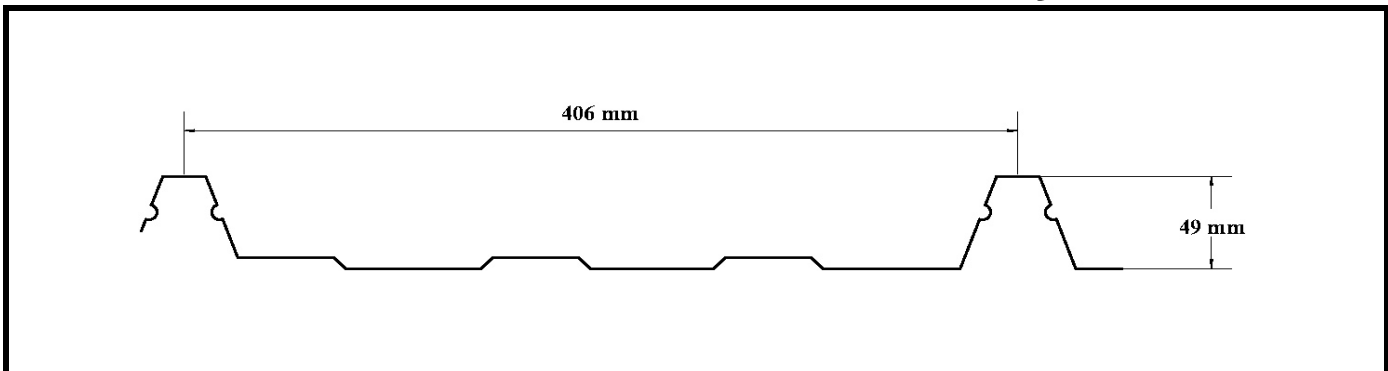

## Properties for Mercury SNAP-RIB II ( Per meter width )

Gauge Number	Base Steel Nominal Thickness	Weight	Overall Depth	MID - SPAN					SUPPORT					Coeff. of Deflect. L/180	Bearing Resist. for 50 mm	
				Section Modulus	Coeff. of Stress	Moment of Inertia		Section Modulus	Coeff. of Stress	Moment of Inertia		EXT	INT			
	mm	Kpa	mm	Sm	mm <sup>3</sup>	Csm	Im	mm <sup>4</sup>	Ss	mm <sup>3</sup>	Css			Is	mm <sup>4</sup>	kN / M
26	0.46	0.0528	49	6.062	10.039	204.5	2.821	4.6716	79.7	17.713	1.86	2.75				
24	0.61	0.0704	49	8.206	13.589	276.1	4.1480	6.8691	114.8	23.910	3.08	5.28				
22	0.76	0.0879	49	10.341	17.125	347.4	5.6500	9.3564	153.2	30.087	4.55	8.65				

## Specified Load Tables - Kpa ( Kn/m<sup>2</sup> )

Span M.	ONE SPAN								TWO EQUAL SPANS								THREE EQUAL SPANS							
	0.46		0.61		0.76				0.46		0.61		0.76				0.46		0.61		0.76			
	A	B	A	B	A	B	A	B	A	B	A	B	A	B	A	B	A	B	A	B	A	B	A	B
0.6	4.1	*	6.8	*	10	*			3.1	*	5.9	*	9.6	*			3.1	*	5.9	*	9.6	*		
0.8	3.1	*	5.1	*	7.6	*			2.3	*	4.4	*	7.2	*			2.3	*	4.4	*	7.2	*		
1.0	2.5	*	4.1	*	6.1	*			1.8	*	3.5	*	5.8	*			1.8	*	3.5	*	5.8	*		
1.2	2.1	*	3.4	*	5.1	*			1.5	*	2.9	*	4.3	*			1.5	*	2.9	*	4.8	*		
1.4	1.8	*	2.9	*	4.3	*			1.3	*	2.3	*	3.2	*			1.3	*	2.5	*	4.0	*		
1.6	1.5	*	2.6	*	3.8	*			1.1	*	1.8	*	2.4	*			1.1	*	2.2	*	3.0	*		
1.8	1.4	*	2.3	*	3.4	*			1.0	*	1.4	*	1.9	*			1.0	*	1.8	*	2.4	*		
2.0	1.2	*	2.1	2.0	2.9	2.5			0.8	*	1.1	*	1.6	*			0.9	*	1.4	*	1.9	*		
2.2	1.1	*	1.9	1.5	2.4	1.9			0.6	*	0.9	*	1.3	*			0.8	*	1.2	*	1.6	*		
2.4	1.0	0.9	1.6	1.2	2.0	1.5			0.5	*	0.8	*	1.1	*			0.7	*	1.0	*	1.4	*		
2.6	1.0	0.7	1.3	0.9	1.7	1.1			0.5	*	0.7	*	0.9	*			0.6	*	0.8	*	1.2	*		
2.8	0.9	0.5	1.2	0.7	1.5	0.9			0.4	0.7	0.6	1.3	0.8	2.1			0.5	0.7	0.7	1.3	1.0	1.7		

### Mercury SNAP-RIB II Load Table Notes

- Column 'A' - Loads based on stress. Column 'B' - Loads based on L / 180 deflection. ( \* ) denotes stress governs.
- Table lists lower value of bending or bearing resistance. *Italic* denotes web crippling governs.
- For deflection loads other than L / 180 multiply column 'B' by the following factors:

DEFLECTION	MULTIPLIER
L / 90	2
L / 240	0.75
L / 360	0.5

- Load tables based on use of A653M Structural Quality Steel Sheet Grade 230 ( maximum stress 207 Mpa ).

# MERCURY METALS LTD.

Imperial - L.S.D. S136-94

Mercury RIB-ROOF

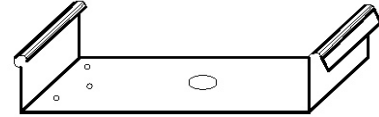
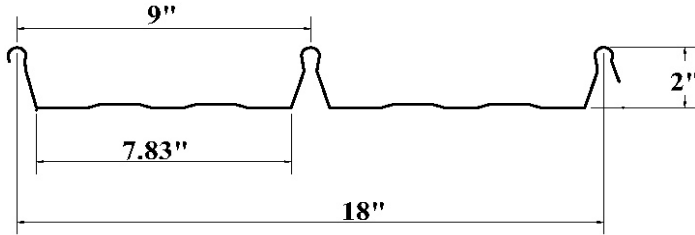

RIB ROOF CLIP

## Properties for Mercury RIB ROOF

( Per foot width )

Gauge Number	Base Steel Nominal Thickness Inches	Weight PSF	Overall Depth Inches	MID - SPAN						SUPPORT				Coeff. of Deflect.		Bearing Resist. 2" K / FT.		
				Section Modulus		Coeff. of Stress Csm	Moment of Inertia		Section Modulus		Coeff. of Stress Css	Moment of Inertia		L / 180	EXT	INT		
				Sm	In3		Im	In4	Ss	In3		Is	In4					
26	0.018	1.200	2	0.0626		1240		0.1017		0.0677		1341		0.1015		8870	0.24	0.44
24	0.024	1.600	2	0.0910		1804		0.1392		0.0754		1493		0.1068		12140	0.39	0.81
22	0.030	1.900	2	0.1119		2216		0.1711		0.0959		1899		0.1278		14923	0.58	1.28

## Specified Load Tables - psf

Span Ft.	ONE SPAN								TWO EQUAL SPANS								THREE EQUAL SPANS							
	0.018		0.024		0.030				0.018		0.024		0.030				0.018		0.024		0.030			
	A	B	A	B	A	B	A	B	A	B	A	B	A	B	A	B	A	B	A	B	A	B	A	B
2.0	157	*	260	*	369	*			146	*	249	*	316	*			146	*	260	*	384	*		
2.5	126	*	192	*	236	*			117	*	159	*	203	*			117	*	199	*	253	*		
3.0	92	*	134	*	164	*			98	*	111	*	141	*			98	*	138	*	176	*		
3.5	67	*	98	*	121	*			73	*	81	*	103	*			84	*	102	*	129	*		
4.0	52	*	75	*	92	*			56	*	62	*	79	*			70	*	78	*	99	*		
4.5	41	*	59	*	73	*			44	*	49	*	63	*			55	*	61	*	78	*		
5.0	33	*	48	*	59	*			36	*	40	*	51	*			45	*	50	*	63	*		
5.5	27	*	40	*	49	*			30	*	33	*	42	*			37	*	41	*	52	*		
6.0	23	*	33	*	41	*			25	*	28	*	35	*			31	*	35	*	44	*		
6.5	20	*	28	*	35	*			21	*	24	*	30	*			26	*	29	*	37	*		
7.0	17	*	25	*	30	*			18	*	20	*	26	*			23	*	25	*	32	*		
7.5	15	*	21	*	26	*			16	*	18	*	23	*			20	*	22	*	28	*		

### Mercury RIB-ROOF Load Table Notes

- 1) Column 'A' - Loads based on stress. Column 'B' - Loads based on L / 180 deflection. ( \* ) denotes stress governs.
- 2) Table lists lower value of bending or bearing resistance. *Italic* denotes web crippling.
- 3) For deflection loads other than L / 180 multiply column 'B' by the following factors:

DEFLECTION	MULTIPLIER
L / 240	0.75
L / 360	0.5

- 4) Load tables based on use of A653 Structural Quality Steel Sheet Grade 33 ( maximum stress 29.7 Ksi ).

# MERCURY METALS

Metric - L.S.D. S136-94

## Mercury RIB-ROOF

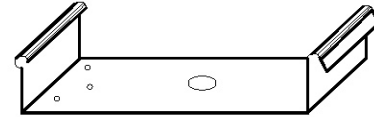
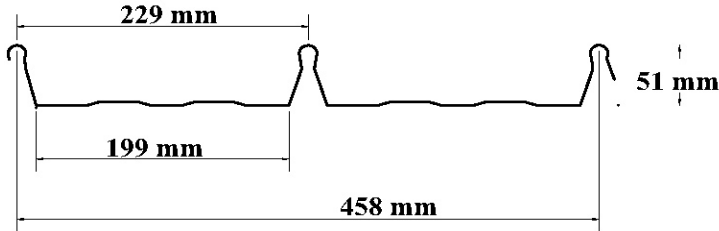

RIB ROOF CLIP

### Properties for Mercury RIB-ROOF

( Per meter width )

Gauge Number	Base Steel Nominal Thickness mm	Weight Kpa	Overall Depth mm	MID - SPAN			SUPPORT			Coeff. of Deflect. L / 180	Bearing Resist. for 50 mm	
				Section Modulus Sm mm <sup>3</sup>	Coeff. of Stress Csm	Moment of Inertia Im mm <sup>4</sup>	Section Modulus Ss mm <sup>3</sup>	Coeff. of Stress Css	Moment of Inertia Is mm <sup>4</sup>		EXT	INT
26	0.46	0.0574	50.8	1.026	1.6987	42.3	1.109	1.8372	42.2	3.6663	3.43	6.41
24	0.61	0.0766	50.8	1.493	2.4722	57.9	1.236	2.0461	44.4	5.0183	5.68	11.8
22	0.76	0.0910	50.8	1.834	3.0366	71.2	1.572	2.6024	53.2	6.1684	8.39	18.7

### Specified Load Tables - Kpa ( Kn/m<sup>2</sup> )

Span M.	ONE SPAN								TWO EQUAL SPANS								THREE EQUAL SPANS							
	0.46		0.61		0.76				0.46		0.61		0.76				0.46		0.61		0.76			
	A	B	A	B	A	B	A	B	A	B	A	B	A	B	A	B	A	B	A	B	A	B	A	B
0.4	7.1	*	10.3	*	12.7	*			7.7	*	8.5	*	10.8	*			9.6	*	10.7	*	13.6	*		
0.6	3.1	*	4.6	*	5.6	*			3.4	*	3.8	*	4.8	*			4.3	*	4.7	*	6.0	*		
0.8	1.8	*	2.6	*	3.2	*			1.9	*	2.1	*	2.7	*			2.4	*	2.7	*	3.4	*		
1.0	1.1	*	1.6	*	2.0	*			1.2	*	1.4	*	1.7	*			1.5	*	1.7	*	2.2	*		
1.2	0.8	*	1.1	*	1.4	*			0.9	*	0.9	*	1.2	*			1.1	*	1.2	*	1.5	*		
1.4	0.6	*	0.8	*	1.0	*			0.6	*	0.7	*	0.9	*			0.8	*	0.9	*	1.1	*		
1.6	0.4	*	0.6	*	0.8	*			0.5	*	0.5	*	0.7	*			0.6	*	0.7	*	0.8	*		
1.8	0.3	*	0.5	*	0.6	*			0.4	*	0.4	*	0.5	*			0.5	*	0.5	*	0.7	*		
2.0	0.3	*	0.4	*	0.5	*			0.3	*	0.3	*	0.4	*			0.4	*	0.4	*	0.5	*		
2.2	0.2	*	0.3	*	0.4	*			0.3	*	0.3	*	0.4	*			0.3	*	0.4	*	0.4	*		
2.4	0.2	*	0.3	*	0.4	0.4			0.2	*	0.2	*	0.3	*			0.3	*	0.3	*	0.4	*		
2.6	0.2	0.2	0.2	*	0.3	0.4			0.2	*	0.2	*	0.3	*			0.2	*	0.3	*	0.3	*		

#### Mercury RIB-ROOF Load Table Notes

- 1) Column 'A' - Loads based on stress. Column 'B' - Loads based on L / 180 deflection. ( \* ) denotes stress governs.
- 2) Table lists lower value of bending or bearing resistance. *Italic* denotes web crippling governs.
- 3) For deflection loads other than L / 180 multiply column 'B' by the following factors:

<u>DEFLECTION</u>	<u>MULTIPLIER</u>
L / 240	0.75
L / 360	0.5
- 4) Load tables based on use of A653M Structural Quality Steel Sheet Grade 230 ( maximum stress 207 Mpa ).

# MERCURY METALS

Imperial - L.S.D. S136-94

Mercury PRIME RIB - F

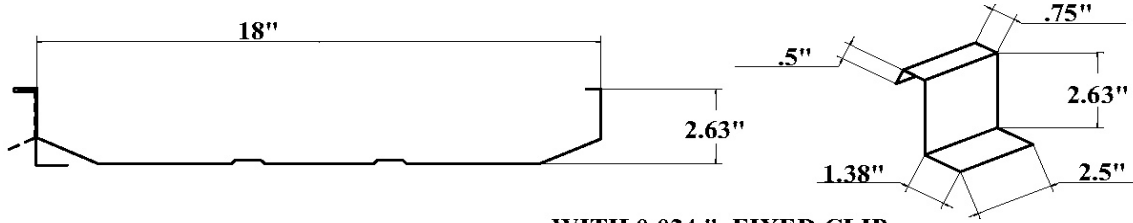

WITH 0.024 " FIXED CLIP

## Properties for Mercury PRIME RIB - F ( Per foot width )

Gauge Number	Base Steel Nominal Thickness Inches	Weight PSF	Overall Depth Inches	MID - SPAN						SUPPORT						Coeff. of Deflect. L / 180	Bearing Res. 2.5" K / FT.	
				Section Modulus		Coeff. of Stress Csm	Moment of Inertia		Section Modulus		Coeff. of Stress Css	Moment of Inertia		EXT	INT			
				Sm	In3		Im	In4	Ss	In3		Is	In4					
26	0.018	0.980	2.625	0.0789		1562	0.1875		0.0773		1531	0.1160	16353	0.23	0.35			
24	0.024	1.307	2.625	0.1211		2398	0.2658		0.1266		2506	0.1707	23182	0.23	0.35			
22	0.030	1.633	2.625	0.1702		3370	0.3652		0.1663		3293	0.2267	31851	0.23	0.35			

## Specified Load Tables - psf

Span Ft.	ONE SPAN								TWO EQUAL SPANS								THREE EQUAL SPANS							
	0.018		0.024		0.030				0.018		0.024		0.030				0.018		0.024		0.030			
	A	B	A	B	A	B	A	B	A	B	A	B	A	B	A	B	A	B	A	B	A	B	A	B
2.0	156	*	156	*	156	*			118	*	118	*	118	*			118	*	118	*	118	*		
2.5	125	*	125	*	125	*			94	*	94	*	94	*			94	*	94	*	94	*		
3.0	104	*	104	*	104	*			79	*	79	*	79	*			79	*	79	*	79	*		
3.5	85	*	89	*	89	*			67	*	67	*	67	*			67	*	67	*	67	*		
4.0	65	*	78	*	78	*			59	*	59	*	59	*			59	*	59	*	59	*		
4.5	51	*	70	*	70	*			50	*	52	*	52	*			52	*	52	*	52	*		
5.0	42	*	63	*	63	*			41	*	47	*	47	*			47	*	47	*	47	*		
5.5	34	*	53	*	57	*			34	*	43	*	43	*			42	*	43	*	43	*		
6.0	29	*	44	*	52	*			28	*	39	*	39	*			35	*	39	*	39	*		
6.5	25	*	38	*	48	*			24	*	36	*	36	*			30	*	36	*	36	*		
7.0	21	*	33	*	45	*			21	*	34	*	34	*			26	*	34	*	34	*		
7.5	19	*	28	*	40	*			18	*	30	*	31	*			23	*	31	*	31	*		

### Mercury PRIME RIB - F Load Table Notes

- 1) Column 'A' - Loads based on stress. Column 'B' - Loads based on L / 180 deflection. ( \* ) denotes stress governs.
- 2) Table lists lower value of bending or bearing resistance. *Italic* denotes web crippling governs.
- 3) For deflection loads other than L / 180 multiply column 'B' by the following factors:

<u>DEFLECTION</u>	<u>MULTIPLIER</u>
L / 240	0.75
L / 360	0.5
- 4) Load tables based on use of A563 Structural Quality Steel Sheet Grade 33 ( maximum stress 29.7 Ksi ).

# MERCURY METALS

Metric - L.S.D. S136-94

Mercury PRIME RIB - F

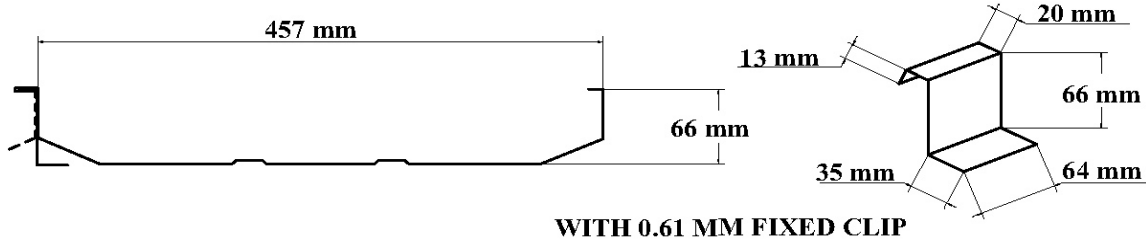

## Properties for Mercury PRIME RIB - F (Per meter width)

Gauge Number	Base Steel Nominal Thickness	Weight	Overall Depth	MID - SPAN				SUPPORT				Coeff. of Deflect.	Bearing Resist. for 63.5 mm		
				Section Modulus	Coeff. of Stress	Moment of Inertia		Section Modulus	Coeff. of Stress	Moment of Inertia			L/180	kN / M	
	mm	Kpa	mm	Sm	mm <sup>3</sup>	Csm	Im	mm <sup>4</sup>	Ss	mm <sup>3</sup>	Css	Is	mm <sup>4</sup>		EXT
26	0.46	0.0469	66	4.244	7.0281	256.0		4.154	6.8790	158.4		22.1754	3.42	5.16	
24	0.61	0.0626	66	6.508	10.7772	363.0		6.805	11.2691	233.0		31.4386	3.42	5.16	
22	0.76	0.0782	66	9.152	15.1557	498.7		8.941	14.8063	309.5		43.01907	3.42	5.16	

## Specified Load Tables - Kpa (Kn/m<sup>2</sup>)

Span M.	ONE SPAN								TWO EQUAL SPANS								THREE EQUAL SPANS							
	0.46		0.61		0.76				0.46		0.61		0.76				0.46		0.61		0.76			
	A	B	A	B	A	B	A	B	A	B	A	B	A	B	A	B	A	B	A	B	A	B	A	B
0.8	5.7	*	5.7	*	5.7	*			4.3	*	4.3	*	4.3	*			4.3	*	4.3	*	4.3	*		
1.0	4.6	*	4.6	*	4.6	*			3.4	*	3.4	*	3.4	*			3.4	*	3.4	*	3.4	*		
1.2	3.3	*	3.8	*	3.8	*			2.9	*	2.9	*	2.9	*			2.9	*	2.9	*	2.9	*		
1.4	2.4	*	3.3	*	3.3	*			2.3	*	2.5	*	2.5	*			2.5	*	2.5	*	2.5	*		
1.6	1.8	*	2.8	*	2.9	*			1.8	*	2.2	*	2.2	*			2.2	*	2.2	*	2.2	*		
1.8	1.4	*	2.2	*	2.5	*			1.4	*	1.9	*	1.9	*			1.8	*	1.9	*	1.9	*		
2.0	1.2	*	1.8	*	2.3	*			1.1	*	1.7	*	1.7	*			1.4	*	1.7	*	1.7	*		
2.2	1.0	*	1.5	*	2.1	*			0.9	*	1.6	*	1.6	*			1.2	*	1.6	*	1.6	*		
2.4	0.8	*	1.2	*	1.8	*			0.8	*	1.3	*	1.4	*			1.0	*	1.4	*	1.4	*		
2.6	0.7	*	1.1	*	1.5	*			0.7	*	1.1	*	1.3	*			0.8	*	1.3	*	1.3	*		
2.8	0.6	*	0.9	*	1.3	*			0.6	*	1.0	*	1.2	*			0.7	*	1.2	*	1.2	*		
3.0	0.5	*	0.8	*	1.1	*			0.5	*	0.8	*	1.1	*			0.6	*	1.0	*	1.1	*		

### Mercury PRIME RIB - F Load Table Notes

- Column 'A' - Loads based on stress. Column 'B' - Loads based on L / 180 deflection. ( \* ) denotes stress governs.
- Table lists lower value of bending or bearing resistance. *Italic* denotes web crippling governs.
- For deflection loads other than L / 180 multiply column 'B' by the following factors:

<u>DEFLECTION</u>	<u>MULTIPLIER</u>
L / 240	0.75
L / 360	0.5
- Load tables based on use of A653M Structural Quality Steel Sheet Grade 230 ( maximum stress 207 Mpa ).

# MERCURY METALS

Imperial - L.S.D. S136-94

## Mercury PRIME RIB - E

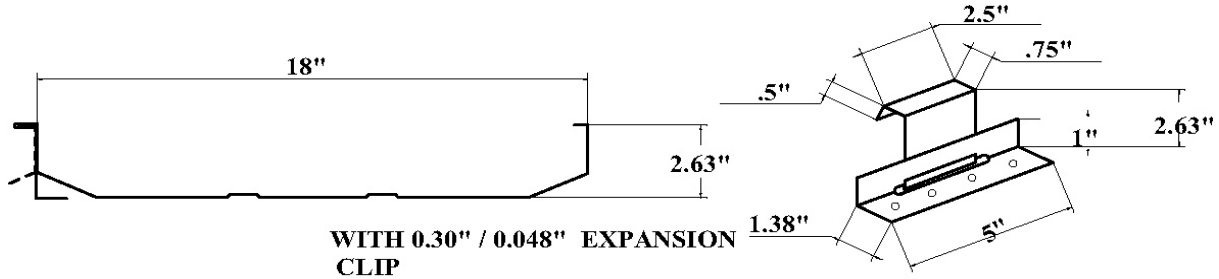

### Properties for Mercury PRIME RIB - E ( Per foot width)

Gauge Number	Base Steel Nominal Thickness Inches	Weight PSF	Overall Depth Inches	MID - SPAN						SUPPORT						Coeff. of Deflect. L / 180	Bearing Res. 2.5" K / FT.	
				Section Modulus		Coeff. of Stress Csm	Moment of Inertia		Section Modulus		Coeff. of Stress Css	Moment of Inertia		L / 180	EXT		INT	
				Sm	In3		Im	In4	Ss	In3		Is	In4					
26	0.018	0.980	2.625	0.0789		1562	0.1875	0.0773		1531	0.1160	16353	0.43	0.85				
24	0.024	1.307	2.625	0.1211		2398	0.2658	0.1266		2507	0.1707	23182	0.43	0.85				
22	0.030	1.633	2.625	0.1702		3370	0.3652	0.1663		3293	0.2267	31851	0.43	0.85				

### Specified Load Tables - psf

Span Ft.	ONE SPAN								TWO EQUAL SPANS								THREE EQUAL SPANS							
	0.018		0.024		0.030				0.018		0.024		0.030				0.018		0.024		0.030			
	A	B	A	B	A	B	A	B	A	B	A	B	A	B	A	B	A	B	A	B	A	B	A	B
2.0	260	*	286	*	286	*			255	*	283	*	283	*			283	*	283	*	283	*		
2.5	167	*	229	*	229	*			163	*	226	*	226	*			204	*	226	*	226	*		
3.0	116	*	178	*	191	*			113	*	186	*	189	*			142	*	189	*	189	*		
3.5	85	*	130	*	163	*			83	*	136	*	162	*			104	*	162	*	162	*		
4.0	65	*	100	*	140	*			64	*	104	*	137	*			80	*	131	*	142	*		
4.5	51	*	79	*	111	*			50	*	83	*	108	*			63	*	103	*	126	*		
5.0	42	*	64	*	90	*			41	*	67	*	88	*			51	*	84	*	110	*		
5.5	34	*	53	*	74	*			34	*	55	*	73	*			42	*	69	*	91	*		
6.0	29	*	44	*	62	*			28	*	46	*	61	*			35	*	58	*	76	*		
6.5	25	*	38	*	53	*			24	*	40	*	52	*			30	*	49	*	65	*		
7.0	21	*	33	*	46	*			21	*	34	*	45	*			26	*	43	*	56	*		
7.5	19	*	28	*	40	*			18	*	30	*	39	*			23	*	37	*	49	*		

#### Mercury PRIME RIB - E Load Table Notes

- 1) Column 'A' - Loads based on stress. Column 'B' - Loads based on L / 180 deflection. ( \* ) denotes stress governs.
- 2) Table lists lower value of bending or bearing resistance. *Italic* denotes web crippling governs.
- 3) For deflection loads other than L / 180 multiply column 'B' by the following factors:

<u>DEFLECTION</u>	<u>MULTIPLIER</u>
L / 240	0.75
L / 360	0.5
- 4) Load tables based on use of A653 Structural Quality Steel Sheet Grade 33 ( maximum stress 29.7 Ksi ).

# MERCURY METALS

Metric - L.S.D. S136-94

Mercury PRIME RIB - E

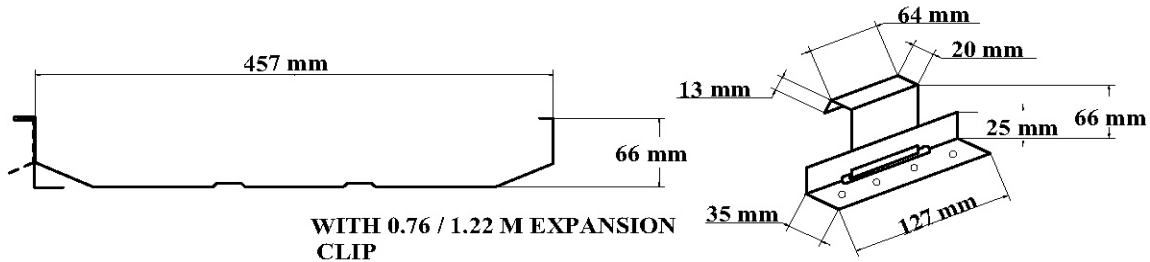

## Properties for Mercury PRIME RIB - E ( Per meter width )

Gauge Number	Base Steel Nominal Thickness mm	Weight Kpa	Overall Depth mm	MID - SPAN					SUPPORT					Coeff. of Deflect. L/180	Bearing Resist. for 63.5 mm	
				Section Modulus Sm	Coeff. of Stress Csm	Moment of Inertia		Section Modulus Ss	Coeff. of Stress Css	Moment of Inertia		EXT	INT			
						mm <sup>3</sup>	mm <sup>4</sup>			mm <sup>3</sup>	mm <sup>4</sup>					
26	0.46	0.0469	66	4.244	7.0281	256.0		4.154	6.8790	158.4		22.1754	6.26	11.4		
24	0.61	0.0626	66	6.5080	10.7772	363.0		6.805	11.2691	233.0		31.4386	6.26	11.4		
22	0.76	0.0782	66	9.1520	15.1557	498.7		8.941	14.8063	309.5		43.01907	6.26	11.4		

## Specified Load Tables - Kpa ( Kn/m<sup>2</sup> )

Span M.	ONE SPAN								TWO EQUAL SPANS								THREE EQUAL SPANS							
	0.46		0.61		0.76				0.46		0.61		0.76				0.46		0.61		0.76			
	A	B	A	B	A	B	A	B	A	B	A	B	A	B	A	B	A	B	A	B	A	B	A	B
0.8	7.3	*	10	*	10	*			7.2	*	9.5	*	9.5	*			9.0	*	9.5	*	9.5	*		
1.0	4.7	*	7.2	*	8.3	*			4.6	*	7.5	*	7.6	*			5.7	*	7.6	*	7.6	*		
1.2	3.3	*	5.0	*	7.0	*			3.2	*	5.2	*	6.3	*			4.0	*	6.3	*	6.3	*		
1.4	2.4	*	3.7	*	5.2	*			2.3	*	3.8	*	5.0	*			2.9	*	4.8	*	5.4	*		
1.6	1.8	*	2.8	*	3.9	*			1.8	*	2.9	*	3.9	*			2.2	*	3.7	*	4.7	*		
1.8	1.4	*	2.2	*	3.1	*			1.4	*	2.3	*	3.0	*			1.8	*	2.9	*	3.8	*		
2.0	1.2	*	1.8	*	2.5	*			1.1	*	1.9	*	2.5	*			1.4	*	2.3	*	3.1	*		
2.2	1.0	*	1.5	*	2.1	*			0.9	*	1.6	*	2.0	*			1.2	*	1.9	*	2.5	*		
2.4	0.8	*	1.2	*	1.8	*			0.8	*	1.3	*	1.7	*			1.0	*	1.6	*	2.1	*		
2.6	0.7	*	1.1	*	1.5	*			0.7	*	1.1	*	1.5	*			0.8	*	1.4	*	1.8	*		
2.8	0.6	*	0.9	*	1.3	*			0.6	*	1.0	*	1.3	*			0.7	*	1.2	*	1.6	*		
3.0	0.5	*	0.8	*	1.1	*			0.5	*	0.8	*	1.1	*			0.6	*	1.0	*	1.4	*		

### Mercury PRIME RIB - E Load Table Notes

- Column 'A' - Loads based on stress. Column 'B' - Loads based on L / 180 deflection. ( \* ) denotes stress governs.
- Table lists lower value of bending or bearing resistance. *Italic* denotes web crippling governs.
- For deflection loads other than L / 180 multiply column 'B' by the following factors:

DEFLECTION	MULTIPLIER
L / 240	0.75
L / 360	0.5

- Load tables based on use of A653M Structural Quality Steel Sheet Grade 230 ( maximum stress 207 Mpa ).

# MERCURY METALS

Imperial - L.S.D. S136-94

## Mercury REDI RIB

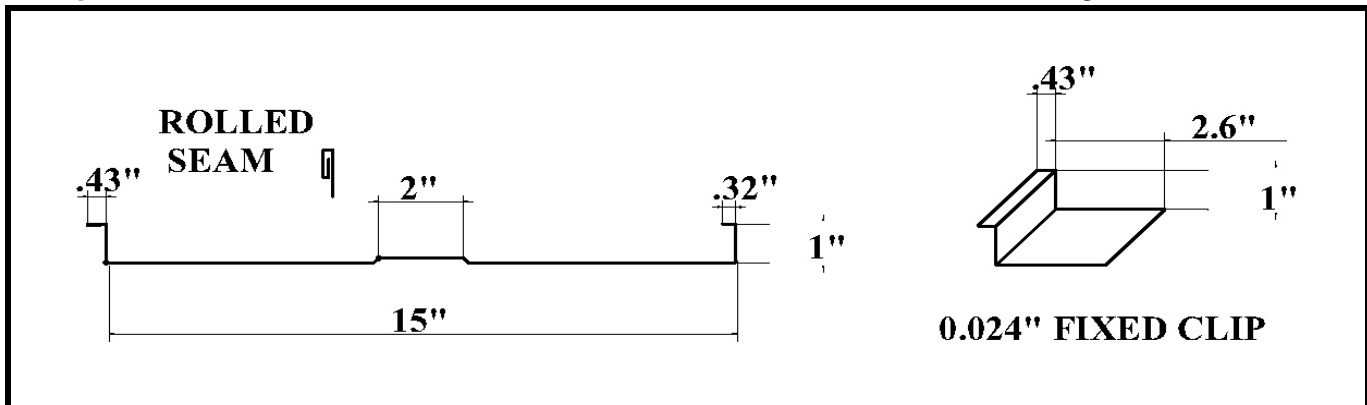

### Properties for Mercury REDI RIB

( Per foot width)

Gauge Number	Base Steel Nominal Thickness Inches	Weight PSF	Overall Depth Inches	MID - SPAN					SUPPORT					Coeff. of Deflect. L / 180	Bearing Resist. 2"	
				Section Modulus		Coeff. of Stress Csm	Moment of Inertia		Section Modulus		Coeff. of Stress Css	Moment of Inertia			EXT	INT
				Sm	In3		Im	In4	Ss	In3		Is	In4			
26	0.018	0.919	1	0.0211		418	0.0181		0.0237		469	0.0112	1579	0.11	0.21	
24	0.024	1.225	1	0.0281		556	0.024		0.0364		721	0.0162	2093	0.19	0.46	
22	0.030	1.531	1	0.0352		697	0.0301		0.0517		1024	0.0215	2625	0.28	0.65	
20	0.036	1.837	1	0.0427		846	0.0365		0.0696		1378	0.0273	3183	0.39	0.96	

### Specified Load Tables - psf

Span Ft.	ONE SPAN								TWO EQUAL SPANS								THREE EQUAL SPANS							
	0.018		0.024		0.030		0.036		0.018		0.024		0.030		0.036		0.018		0.024		0.030		0.036	
	A	B	A	B	A	B	A	B	A	B	A	B	A	B	A	B	A	B	A	B	A	B	A	B
1.0	148	*	250	*	375	*	523	*	138	*	250	*	375	*	523	*	138	*	250	*	375	*	523	*
1.5	99	*	165	*	207	*	251	*	92	*	167	*	250	*	348	*	92	*	167	*	250	*	348	*
2.0	70	*	93	*	116	*	141	*	69	*	120	*	171	*	230	*	69	*	125	*	181	*	220	*
2.5	45	*	59	*	74	*	90	*	50	*	77	*	109	*	147	*	55	*	93	*	116	*	141	*
3.0	31	*	41	*	52	*	63	*	35	*	53	*	76	*	102	*	43	*	64	*	81	*	98	*
3.5	23	*	30	*	38	*	46	*	26	*	39	*	56	*	75	*	32	*	47	*	59	*	72	*
4.0	17	16	23	22	29	27	35	33	20	*	30	*	43	*	57	*	24	*	36	*	45	*	55	*
4.5	14	12	18	15	23	19	28	23	15	*	24	*	34	*	45	*	19	*	29	29	36	36	43	*
5.0	11	8	15	11	19	14	23	17	13	*	19	*	27	*	37	*	16	16	23	21	29	26	35	32
5.5	9	6	12	8	15	11	19	13	10	*	16	*	23	*	30	*	13	12	19	16	24	20	29	24
6.0	8	5	10	6	13	8	16	10	9	*	13	*	19	19	26	24	11	9	16	12	20	15	24	19
6.5	7	4	9	5	11	6	13	8	7	*	11	*	16	15	22	19	9	7	14	10	17	12	21	15

#### Mercury REDI RIB Load Table Notes

- 1) Column 'A' - Loads based on stress. Column 'B' - Loads based on L / 180 deflection. ( \* ) denotes stress governs.
- 2) Table lists lower value of bending or bearing resistance. *Italic* denotes web crippling governs.
- 3) For deflection loads other than L / 180 multiply column 'B' by the following factors:

<u>DEFLECTION</u>	<u>MULTIPLIER</u>
L / 240	0.75
L / 360	0.5
- 4) Load tables based on use of A653 Structural Quality Steel Sheet Grade 33 ( maximum stress 29.7 Ksi ).

# MERCURY METALS

Metric - L.S.D. S136-94

Mercury REDI RIB

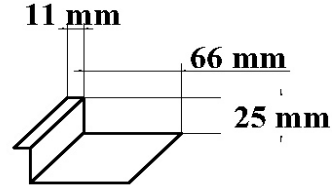
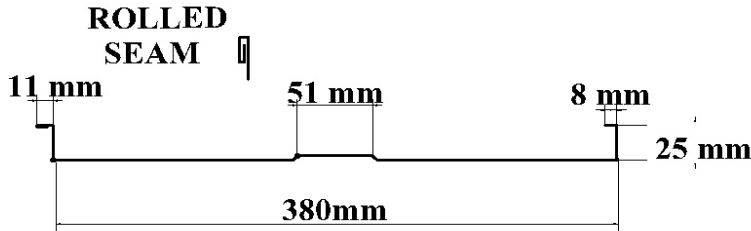

0.61 mm FIXED CLIP

## Properties for Mercury REDI RIB

( Per meter width )

Gauge Number	Base Steel Nominal Thickness mm	Weight Kpa	Overall Depth mm	MID - SPAN						SUPPORT						COEFF. OF DEFLECT. L/180	BEARING RESIST.	
				Section Modulus		Coeff. of Stress Csm	Moment of Inertia		Section Modulus		Coeff. of Stress Css	Moment of Inertia		EXT	INT			
				Sm	mm <sup>3</sup>		Im	mm <sup>4</sup>	Ss	mm <sup>3</sup>		Is	mm <sup>4</sup>					
				x10 <sup>3</sup>		x10 <sup>3</sup>		x10 <sup>3</sup>		x10 <sup>3</sup>								
26	0.46	0.0440	25	1.133	1.8762	24.7	1.273	2.1081	13.7	2.1389	1.62	3.02						
24	0.61	0.0586	25	1.510	2.5006	32.8	1.955	3.2375	22.1	2.8420	2.77	5.77						
22	0.76	0.0733	25	1.893	3.1348	41.1	2.780	4.6037	29.3	3.5608	4.10	9.41						
20	0.91	0.0879	25	2.295	3.8005	49.8	3.740	6.1934	37.2	4.3140	5.72	13.9						

## Specified Load Tables - Kpa ( Kn/m<sup>2</sup> )

Span M.	ONE SPAN								TWO EQUAL SPANS								THREE EQUAL SPANS							
	0.46		0.61		0.76		0.91		0.46		0.61		0.76		0.91		0.46		0.61		0.76		0.91	
	A	B	A	B	A	B	A	B	A	B	A	B	A	B	A	B	A	B	A	B	A	B	A	B
0.4	5.4	*	9.2	*	13.1	*	15.8	*	5.0	*	9.2	*	14	*	19	*	5.0	*	9.2	*	14	*	19	*
0.5	4.3	*	6.7	*	8.4	*	10.1	*	4.0	*	7.4	*	11	*	15	*	4.0	*	7.4	*	11	*	15	*
0.6	3.5	*	4.6	*	5.8	*	7.0	*	3.4	*	6.0	*	8.5	*	11.5	*	3.4	*	6.2	*	9	*	11.0	*
0.7	2.6	*	3.4	*	4.3	*	5.2	*	2.9	*	4.4	*	6.3	*	8.4	*	2.9	*	5.3	*	6.7	*	8.1	*
0.8	2.0	*	2.6	*	3.3	*	4.0	*	2.2	*	3.4	*	4.8	*	6.5	*	2.5	*	4.1	*	5.1	*	6.2	*
0.9	1.5	*	2.1	*	2.6	*	3.1	*	1.7	*	2.7	*	3.8	*	5.1	*	2.2	*	3.2	*	4.0	*	4.9	*
1.0	1.3	*	1.7	*	2.1	*	2.5	*	1.4	*	2.2	*	3.1	*	4.1	*	1.8	*	2.6	*	3.3	*	4.0	*
1.2	0.9	0.8	1.2	1.1	1.5	1.4	1.8	1.7	1.0	*	1.5	*	2.1	*	2.9	*	1.2	*	1.8	*	2.3	*	2.7	*
1.4	0.6	0.5	0.9	0.7	1.1	0.9	1.3	1.0	0.7	*	1.1	*	1.6	*	2.1	*	0.9	*	1.3	1.3	1.7	1.6	2.0	2.0
1.6	0.5	0.3	0.7	0.5	0.8	0.6	1.0	0.7	0.5	*	0.8	*	1.2	*	1.6	*	0.7	0.7	1.0	0.9	1.3	1.1	1.5	1.3
1.8	0.4	0.2	0.5	0.3	0.6	0.4	0.8	0.5	0.4	*	0.7	*	0.9	*	1.3	1.2	0.5	0.5	0.8	0.6	1.0	0.8	1.2	0.9
2.0	0.3	0.2	0.4	0.2	0.5	0.3	0.6	0.4	0.4	0.4	0.5	*	0.8	*	1.0	0.9	0.4	0.3	0.7	0.4	0.8	0.6	1.0	0.7

### Mercury REDI RIB Load Table Notes

- Column 'A' - Loads based on stress. Column 'B' - Loads based on L / 180 deflection. ( \* ) denotes stress governs.
- Table lists lower value of bending or bearing resistance. *Italic* denotes web crippling governs.
- For deflection loads other than L / 180 multiply column 'B' by the following factors:

<u>DEFLECTION</u>	<u>MULTIPLIER</u>
L / 240	0.75
L / 360	0.5
- Load tables based on use of A653M Structural Quality Steel Sheet Grade 230 ( maximum stress 207 Mpa ).