

MERCURY METALS

SPECIFICATION FOR SINGLE SKIN WALL AND/OR ROOF CLADDING

Page 1 of 3

PART 1 – GENERAL

1.1 – GENERAL REQUIREMENTS

1. Division 1, General Requirements, Supplementary General Requirements and Instruction to bidders are part of this specification and shall apply as if repeated here.
2. The requirements for Goods and Services Tax and Provincial Sales Tax are outlined in the General Requirements.

1.2 – SCOPE OF WORK

1. Furnish all materials, labor, equipment and services, necessary for the detailed design erection drawings, shop drawings, fabrication and erection of the complete wall and/or roof cladding as shown or called for in the tender documents.
2. Supply and install accessories where shown or called for by the tender documents.
3. Cut and flash penetrations through the wall and/or roof cladding shown on drawings.

1.3 – SHOP DRAWINGS

1. Submit erection drawings in accordance with General Conditions.
2. Erection drawings shall show clearly the location of various cladding units, section designations, finishes, quantities, fastener specifics and any other information required for erection purposes.
3. Shop drawings shall be signed and sealed by a Specialty Engineer, a Registered Engineer familiar with sheet metal panels components and systems.
4. The Specialty Engineer shall submit the required documentation covering the specified work and conduct field inspections as he deems to be required to assure work is performed in accordance with the shop drawings.

1.4 – WORK NOT INCLUDED

1. Structural steel girts, or other supports, for wall cladding.
2. Structural steel purlins, or other supports, for the roof cladding.
3. Structural framing, or reinforcement, for doors, sash, penetrations or other openings
4. Base angles and caulking of same.
5. Gutters, downspouts, coping trim, cant or parapet flashing, unless shown or called for on the tender documents as being supplied by this division.
6. Overall design of wall and/or roof system for adherence to rainscreen principles, water penetration, internal condensation, air and vapour barriers, insulation design and collateral material selection.

1.5 – STANDARDS

1. Design wall and/or roof cladding in accordance with the latest edition of:
 - i. CAN/C.S.A. – S 136 for the Design of Cold Formed Steel Structural Members.
 - ii. Specified loads, load factors and load distributions shall be in accordance with the National Building code of Canada unless otherwise stated.

1.6 – DESIGN CRITERIA

1. Design wall and/or roof cladding using Limit States Design.
2. Design wall and/or roof cladding to resist:
 - i. Live and dead loads as specified and shown on tender drawings.
 - ii. Net uplift and suction loads as specified and shown on tender drawings.
3. Deflection of wall cladding is not to exceed 1/90 of the span for the specified live loading while deflection of roof cladding is not to exceed 1/180 of the span of the specified live loading.
4. Where possible, span cladding over four or more structural supports (3 continuous spans).

SPECIFICATION FOR SINGLE SKIN WALL AND/OR ROOF CLADDING

5. For exposed metal roof cladding ensure the following minimum roof slopes are being maintained.
 - i. Screwed roof systems – 1 in 12
 - ii. Standing seam roof systems – 1 in 48
6. Standing seam roof systems shall have a shear device to endure transfer of shear loads into the supporting structure.
7. The supporting structure shall provide the floor deck a minimum bearing width equal to the cladding profile depth, but not less than 1.5”.

PART 2 – PRODUCTS

2.1 MATERIALS

1. Manufacturer shall be a member of Good Standing with the Canadian Sheet Steel Building Institute (C.S.S.B.I.).
2. Fabrication from ASTM A 653M SQ (structural quality) grade 230 galvanized steel with a zinc coating of Z275 galvanized as designated by ASTM A653M.
3. Profile designation shall be Mercury _____ complete with prefinish colour QC- _____.
4. Minimum design thickness shall be _____mm (_____in).
5. Prefinished sheet steel, in addition to meeting the requirements of 2.1.2, shall have a 2-coat (minimum) Silicone Modified Polyester Paint System factory applied, cured by baking, using colours of proven durability for exterior exposure.
6. Trim shall be fabricated from the same material, thickness and finish as the respective wall or roof cladding.
7. E.P.T. closures shall be provided, where indicated on the tender documents, to close off the flutes of the cladding at head, sill, base and eaves.
8. Fasteners for attaching cladding to structural framing or other structural supports, for attaching flashing to cladding, and for joining cladding components together shall be as recommended by the Specialty Engineer.
9. Polybutylene Mastic tape caulking of suitable thickness and width will be supply with the cladding panels for the sealing of side and end lap joints.
10. Insulation shall be Metal Building Insulation with a thickness of _____ mm (_____ in) complete with a laminated vapour barrier consisting of _____ complete with 52 mm (2 in) side taps for folding and stapling.

PART 3 – EXECUTION

3.1 STORAGE OF MATERIAL ON SITE

1. Steel sheet cladding shall normally be delivered to the jobsite as required for erection, but if site storage becomes necessary, suitable storage areas shall be provided by the general contractor as close to the building site as is practicable. Preferably this storage shall be under cover.
2. When outdoor storage is unavoidable:
 - a. Use good quality covers, other than plastic, loosely shrouded over stacks and firmly anchored to prevent wind blow-off;
 - b. Tilt bundles for drainage;
 - c. Ventilate bundles but do not allow the entry of wind driven precipitation;
 - d. Block bundles off ground for effective ventilation;
 - e. Block bundles to prevent sagging;
 - f. Store away from chemically aggressive substances (e.g. salt, cement, fertilizer) away from materials that could contaminate the surface (e.g. diesel oil, paint, grease) and away from traffic.
3. Moisture can cause wet storage staining of metallic coated and pre-finished material and usually occurs as a result of:
 - a. Condensation from high humidity air and/or temperature cycling;
 - b. Wet shipping conditions;
 - c. Wind driven rain penetration (outdoor storage).

The usual progression is from water staining to unsightly white staining (dark grey to dull lack on aluminum-zinc alloy coated sheet) to red rust. On material where wet storage staining has occurred, it should be noted that, except for aesthetic considerations, a nominal amount of staining is not detrimental to the functioning of the product.

3.2 INSTALLATION

1. All erection work shall be carried out by trained erection crews all in accordance with the fabricator's and these specifications.
2. Examine and obtain all necessary measurements of previously executed work which may effect the work of this Division.
3. Report any discovered discrepancies to the Architect/Engineer so that instructions may be given for the necessary remedial work.
4. Exercise care in unpacking, moving, storing, handling and placing panels to prevent damage likely to impair the adequacy or appearance of the material in the finished structure.
5. Sheet steel cladding shall be adjusted to final position before being permanently fastened to structural supports.
6. End laps shall be located over supports. Minimum end laps shall be:
 - i. 50mm for wall cladding
 - ii. 100mm for roof cladding used on roofs with a slope of 4 in 12 or more
 - iii. as per fabricators specifications for roofs sloping less than 4 in 12.
7. Sidelaps shall be sealed with continuous lengths of taped caulking where specified and shall be connected at intervals not exceeding 600mm.
8. Openings, and any necessary flashing, shall be provided as called for by the tender documents.
9. If additional openings not shown or called for by the tender documents are required, such openings shall be cut and flashed by the erector, but the cost of such extra work shall be charged to the buyer.
10. When cutting or drilling prefinished material, care shall be exercised to ensure that cuttings do not remain to rust on exposed prefinished surfaces. Where practicable, cutting and drilling shall be conducted so that cuttings do not strike or accumulate on exposed cladding surfaces.

3.3 TOUCH-UP AND CLEANING

1. The contractor shall remove undue grime and dirt from cladding by dry wiping the panels as the material is erected.
2. At completion of the work of this Division, remove any excess materials, debris and equipment pertaining to the work of this Division, from the site.

MERCURY METALS

GENERAL NOTES for WALL CLADDING

IMPERIAL - L.S.D.

Page 1 of 2

DESIGN CRITERIA:

The properties listed in the following tables are based on one foot panel width. The properties of the steel profiles have been computed in accordance with CSA - S136-94 for limit states design.

Cs COEFFICIENT OF STRESS:

To determine the maximum uniform factored load, governed by design stress, and not covered by the load tables, proceed as follows;

a) Simple Span:

$$\frac{C_s (\text{mid-span})}{(\text{span in feet})^2} \quad \text{psf}$$

b) Double Span: use the lessor of the following;

i) $\frac{C_s (\text{support})}{(\text{span in feet})^2}$ psf

ii) $\frac{C_s (\text{mid-span})}{(\text{span in feet})^2} \times 1.77$ psf

c) Triple Span: use the lessor of the following;

i) $\frac{C_s (\text{support})}{(\text{span in feet})^2} \times 1.25$ psf

ii) $\frac{C_s (\text{mid-span})}{(\text{span in feet})^2} \times 1.56$ psf

To determine the maximum specified uniform loads, as listed in the load tables, divide the results of the equations by 1.5.

The loads determined by these formulas are for positive exterior loading on the exterior sheet in the normal position. For negative exterior loading on the exterior sheet in the normal position, or positive exterior loading on the inverted position; interchange the mid-span properties with the support properties.

COEFFICIENT OF DEFLECTION:

To determine the maximum load governed by deflection limitations, and not covered by the load tables, proceed as follows:

a) Simple Span:

$$\frac{C_d}{(\text{span in feet})^3} \quad \text{psf}$$

b) Double Span:

$$\frac{C_d}{(\text{span in feet})^3} \times 2.4 \quad \text{psf}$$

c) Triple Span:

$$\frac{C_d}{(\text{span in feet})^3} \times 1.89 \quad \text{psf}$$

MERCURY METALS

GENERAL NOTES for WALL CLADDING

IMPERIAL - L.S.D.

Page 2 of 2

The normal allowable deflections are as follows:

Wall Cladding: $L / 90$ and $L / 180$ where a span exceeds 10.0 feet.

WEB CRIPPLING:

Reactions at exterior and/or interior supports shall be equal or less than the factored bearing resistance shown on each load table. To determine the maximum uniform factored load, governed by web crippling, and not covered by the load tables, proceed as follows;

Exterior bearing: $2 \times \frac{\text{EXT Bearing Resistance}}{(\text{span in feet})}$

Interior bearing: $\frac{\text{INT Bearing Resistance}}{(\text{span in feet})}$

To determine the maximum specified uniform loads, as listed in the load tables, divide the results of the equations by 1.5.

SPAN TABLE UNITS AND USE:

- The allowable spans shown in the load tables are in feet.
- The "A" column provides the allowable specified load capacity based on strength.
- The " B " column provides the allowable specified load capacity based on serviceability based on deflection requirements shown on each load table sheet.
- The table lists the lower value of bending capacity or web bearing resistance. The load is expressed in *Italics* when bearing capacity governs.
- The loads shown in the tables are specified loads and have not been factored. Strength capacity in column "A" should be checked against the following formula:

$$\text{Specified Load in Table} \geq [\text{Specified Live Load}] + [0.833 \times \text{Specified Dead Load}]$$

- The load tables are based on the material grades and strengths shown on each load table.
- Sloped walls greater than 30 degrees from the vertical are considered roofs and should be designed and detailed accordingly.
- In addition to normal positive wind loads, significant negative wind pressures will occur near building corners. The wall field and sidelaps must be adequately fastened to prevent failure due to positive, negative and gravitational shear forces. Resistance to these forces will depend on the following factors.
 - Regional wind forces.
 - Wall shape and exposure.
 - Cladding profile, gauge, and subgirt system (if applicable)
 - The nature (wood, steel, plywood, concrete) and spacing of the underlying substructure.

It is important that the design of the substructure has taken in consideration the gravity, positive and negative forces that will be applied from the exterior wall system and that adequate fastening of the substructure to the primary structural framing has been reviewed.

For assistance contact your Mercury Metals representative.

For assistance contact your Mercury Metals representative.

MERCURY METALS

GENERAL NOTES for WALL CLADDING

METRIC - L.S.D.

Page 1 of 2

DESIGN CRITERIA:

The properties listed in the following tables are based on one meter panel width. The properties of the steel profiles have been computed in accordance with CSA - S136-94 for limit states design.

Cs COEFFICIENT OF STRESS:

To determine the maximum uniform factored load, governed by design stress, and not covered by the load tables, proceed as follows;

a) Simple Span:

$$\frac{Cs \text{ (mid-span)}}{(\text{span in meters})^2} \quad \text{kPa}$$

b) Double Span: use the lessor of the following;

i) $\frac{Cs \text{ (support)}}{(\text{span in meters})^2} \quad \text{kPa}$

ii) $\frac{Cs \text{ (mid-span)}}{(\text{span in meters})^2} \times 1.77 \quad \text{kPa}$

c) Triple Span: use the lessor of the following;

i) $\frac{Cs \text{ (support)}}{(\text{span in meters})^2} \times 1.25 \quad \text{kPa}$

ii) $\frac{Cs \text{ (mid-span)}}{(\text{span in meters})^2} \times 1.56 \quad \text{kPa}$

To determine the maximum specified uniform loads, as listed in the load tables, divide the results of the equations by 1.5.

The loads determined by these formulas are for positive exterior loading on the exterior sheet in the normal position. For negative exterior loading on the exterior sheet in the normal position, or positive exterior loading on the inverted position; interchange the mid-span properties with the support properties.

COEFFICIENT OF DEFLECTION:

To determine the maximum load governed by deflection limitations, and not covered by the load tables, proceed as follows:

a) Simple Span:

$$\frac{Cd}{(\text{span in meters})^3} \quad \text{kPa}$$

b) Double Span:

$$\frac{Cd}{(\text{span in meters})^3} \times 2.4 \quad \text{kPa}$$

c) Triple Span:

$$\frac{Cd}{(\text{span in meters})^3} \times 1.89 \quad \text{kPa}$$

MERCURY METALS

GENERAL NOTES for WALL CLADDING

METRIC - L.S.D.

Page 2 of 2

The normal allowable deflections are as follows:

Wall Cladding: $L / 90$ and $L / 180$ where a span exceeds 3.0 meters.

WEB CRIPPLING:

Reactions at exterior and/or interior supports shall be equal or less than the factored bearing resistance shown on each load table. To determine the maximum uniform factored load, governed by web crippling, and not covered by the load tables, proceed as follows;

Exterior bearing: $2 \times \frac{\text{EXT Bearing Resistance}}{(\text{span in meters})}$

Interior bearing: $\frac{\text{INT Bearing Resistance}}{(\text{span in meters})}$

To determine the maximum specified uniform loads, as listed in the load tables, divide the results of the equations by 1.5.

SPAN TABLE UNITS AND USE:

- The allowable spans shown in the load tables are in meters.
- The "A" column provides the allowable specified load capacity based on strength.
- The " B " column provides the allowable specified load capacity based on serviceability based on deflection requirements shown on each load table sheet.
- The table lists the lower value of bending capacity or web bearing resistance. The load is expressed in *Italics* when bearing capacity governs.
- The loads shown in the tables are specified loads and have not been factored. Strength capacity in column "A" should be checked against the following formula:

$$\text{Specified Load in Table} > / = [\text{Specified Live Load}] + [0.833 \times \text{Specified Dead Load}]$$

- The load tables are based on the material grades and strengths shown on each load table.
- Sloped walls greater than 30 degrees from the vertical are considered roofs and should be designed and detailed accordingly.
- In addition to normal positive wind loads, significant negative wind pressures will occur near building corners. The wall field and sidelaps must be adequately fastened to prevent failure due to positive, negative and gravitational shear forces. Resistance to these forces will depend on the following factors.
 - Regional wind forces.
 - Wall shape and exposure.
 - Cladding profile, gauge, and subgirt system (if applicable)
 - The nature (wood, steel, plywood, concrete) and spacing of the underlying substructure.It is important that the design of the substructure has taken in consideration the gravity, positive and negative forces that will be applied from the exterior wall system and that adequate fastening of the substructure to the primary structural framing has been reviewed.

For assistance contact your Mercury Metals representative.

MERCURY METALS

Imperial - L.S.D. S136-94

Mercury CL BOLD-RIB

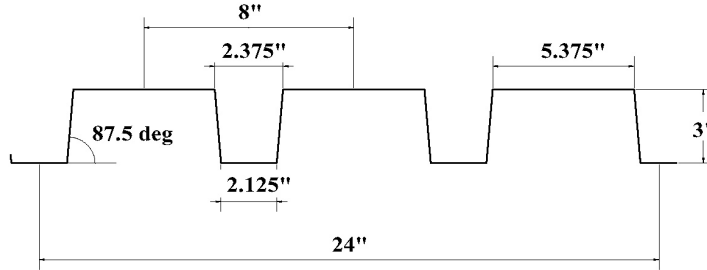

Properties for Mercury CL BOLD-RIB

(Per foot width)

Gauge Number	Base Steel Nominal Thickness Inches	Weight PSF	Overall Depth Inches	MID - SPAN					SUPPORT					Coeff. of Deflect. L / 180	Bearing Resist. 3"	
				Section Modulus		Coeff. of Stress Csm	Moment of Inertia		Section Modulus		Coeff. of Stress Css	Moment of Inertia			EXT	INT
				Sm	In3		Im	In4	Ss	In3		Is	In4			
24	0.024	1.790	3	0.2610	5168	0.4942	0.3271	6477	0.7028	43102	0.50	0.70				
22	0.030	2.160	3	0.3660	7247	0.6620	0.4627	9162	0.9281	57736	0.74	1.18				
20	0.036	2.590	3	0.4763	9431	0.8392	0.5649	11185	1.0679	73191	1.01	1.77				
18	0.048	3.440	3	0.7282	14418	1.2168	0.7785	15414	1.4164	106123	1.68	3.32				

Specified Load Tables - psf

Span Ft.	ONE SPAN								TWO EQUAL SPANS								THREE EQUAL SPANS							
	0.024		0.030		0.036		0.048		0.024		0.030		0.036		0.048		0.024		0.030		0.036		0.048	
	A	B	A	B	A	B	A	B	A	B	A	B	A	B	A	B	A	B	A	B	A	B	A	B
7.0	70	*	99	*	128	*	196	*	67	*	112	*	152	*	210	*	67	*	112	*	169	*	262	*
7.5	61	*	86	*	112	*	171	*	63	*	105	*	133	*	183	*	63	*	105	*	157	*	228	*
8.0	54	*	75	*	98	*	150	*	59	*	95	*	117	*	161	*	59	*	98	*	146	*	201	*
8.5	48	*	67	*	87	*	133	*	55	*	85	*	103	*	142	*	55	*	92	*	129	*	178	*
9.0	43	*	60	*	78	*	119	*	52	*	75	*	92	*	127	*	52	*	87	*	115	*	159	*
9.5	38	*	54	*	70	*	107	*	48	*	68	*	83	*	114	*	49	*	83	*	103	*	142	*
10.0	34	*	48	*	63	*	96	*	43	*	61	*	75	*	103	*	47	*	75	*	93	*	128	*
10.5	31	*	44	*	57	*	87	*	39	*	55	*	68	*	93	*	45	*	68	*	85	*	117	*
11.0	28	*	40	*	52	*	79	*	36	*	50	*	62	*	85	*	43	*	62	*	77	*	106	*
11.5	26	*	37	*	48	48	73	70	33	*	46	*	56	*	78	*	41	*	57	*	70	*	97	*
12.0	24	*	34	33	44	42	67	61	30	*	42	*	52	*	71	*	37	*	52	*	65	*	89	*
12.5	22	22	31	30	40	37	62	54	28	*	39	*	48	*	66	*	34	*	48	*	60	*	82	*

Mercury CL BOLD-RIB Load Table Notes

- 1) Column 'A' - Loads based on stress. Column 'B' - Loads based on L / 180 deflection. (*) denotes stress governs.
- 2) Table lists lower value of bending or bearing resistance. *Italic* denotes web crippling governs.
- 3) For deflection loads other than L / 180 multiply column 'B' by the following factors:

DEFLECTION	MULTIPLIER
L / 240	0.75
L / 360	0.5
- 4) Load tables based on use of A653 Structural Quality Steel Sheet Grade 33 (maximum stress 29.7 Ksi).

MERCURY METALS

Metric - L.S.D. S136-94

Mercury CL BOLD-RIB

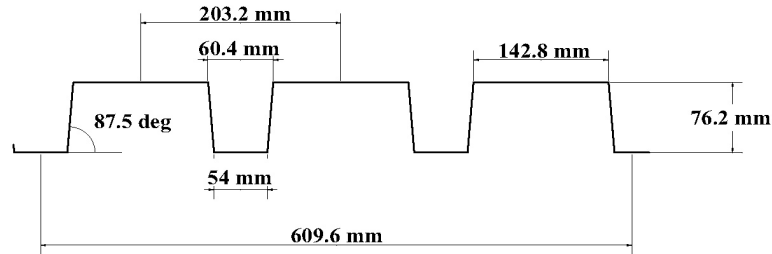

Properties for Mercury CL BOLD-RIB

(Per meter width)

Gauge Number	Base Steel Nominal Thickness	Weight	Overall Depth	MID - SPAN					SUPPORT					Coeff. of Deflect.	Bearing Resist.		
				Section Modulus		Coeff. of Stress	Moment of Inertia		Section Modulus		Coeff. of Stress	Moment of Inertia			L / 180	for 76mm	
				Sm	mm ³		Csm	Im	mm ⁴	Ss		mm ³	Css			Is	mm ⁴
24	0.61	0.0856	76.2	14.035	23.2420	674.8	17.588	29.1257	959.8	58.45	7.26	10.3					
22	0.76	0.1033	76.2	19.676	32.5835	904.1	24.875	41.1930	1267.3	78.30	10.7	17.2					
20	0.91	0.1239	76.2	25.605	42.0190	1146.0	30.371	50.2944	1458.3	99.26	14.8	25.8					
18	1.22	0.1646	76.2	39.146	64.8258	1661.4	41.856	69.3135	1934.3	143.90	24.5	48.5					

Specified Load Tables - Kpa (Kn/m²)

Span M.	ONE SPAN								TWO EQUAL SPANS								THREE EQUAL SPANS							
	0.61		0.76		0.91		1.22		0.61		0.76		0.91		1.22		0.61		0.76		0.91		1.22	
	A	B	A	B	A	B	A	B	A	B	A	B	A	B	A	B	A	B	A	B	A	B	A	B
2.0	3.9	*	5.4	*	7.0	*	10.8	*	3.4	*	5.7	*	8.4	*	11.6	*	3.4	*	5.7	*	8.6	*	14.4	*
2.2	3.2	*	4.5	*	5.8	*	8.9	*	3.1	*	5.2	*	6.9	*	9.5	*	3.1	*	5.2	*	7.8	*	11.9	*
2.4	2.7	*	3.8	*	4.9	*	7.5	*	2.9	*	4.8	*	5.8	*	8.0	*	2.9	*	4.8	*	7.2	*	10.0	*
2.6	2.3	*	3.2	*	4.1	*	6.4	*	2.6	*	4.1	*	5.0	*	6.8	*	2.6	*	4.4	*	6.2	*	8.5	*
2.8	2.0	*	2.8	*	3.6	*	5.5	*	2.4	*	3.5	*	4.3	*	5.9	*	2.4	*	4.1	*	5.3	*	7.4	*
3.0	1.7	*	2.4	*	3.1	*	4.8	*	2.2	*	3.1	*	3.7	*	5.1	*	2.3	*	3.8	*	4.7	*	6.4	*
3.2	1.5	*	2.1	*	2.7	*	4.2	*	1.9	*	2.7	*	3.3	*	4.5	*	2.1	*	3.3	*	4.1	*	5.6	*
3.4	1.3	*	1.9	*	2.4	*	3.7	3.7	1.7	*	2.4	*	2.9	*	4.0	*	2.0	*	2.9	*	3.6	*	5.0	*
3.6	1.2	*	1.7	1.7	2.2	2.1	3.3	3.1	1.5	*	2.1	*	2.6	*	3.6	*	1.9	*	2.6	*	3.2	*	4.5	*
3.8	1.1	1.1	1.5	1.4	1.9	1.8	3.0	2.6	1.3	*	1.9	*	2.3	*	3.2	*	1.7	*	2.3	*	2.9	*	4.0	*
4.0	1.0	0.9	1.4	1.2	1.8	1.6	2.7	2.2	1.2	*	1.7	*	2.1	*	2.9	*	1.5	*	2.1	*	2.6	*	3.6	*
4.2	0.9	0.8	1.2	1.1	1.6	1.3	2.4	1.9	1.1	*	1.6	*	1.9	*	2.6	*	1.4	*	1.9	*	2.4	*	3.3	*

Mercury CL BOLD-RIB Load Table Notes

- Column 'A' - Loads based on stress. Column 'B' - Loads based on L / 180 deflection. (*) denotes stress governs.
- Table lists lower value of bending or bearing resistance. *Italic* denotes web crippling governs.
- For deflection loads other than L / 180 multiply column 'B' by the following factors:

<u>DEFLECTION</u>	<u>MULTIPLIER</u>
L / 240	0.75
L / 360	0.5
- Load tables based on use of A653M Structural Quality Steel Sheet Grade 230 (maximum stress 207 Mpa).

MERCURY METALS

Imperial - L.S.D. S136-94

Mercury CL 900

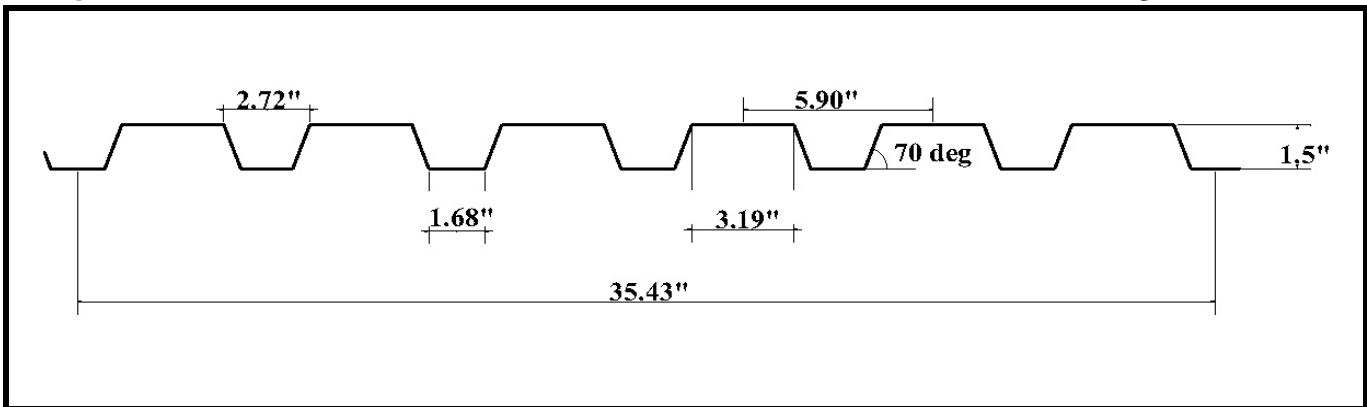

Properties for Mercury CL 900 (Per foot width)

Gauge Number	Base Steel Nominal Thickness Inches	Weight PSF	Overall Depth Dd Inches	MID - SPAN						SUPPORT						Coeff. of Deflect. L / 180	Bearing Resis.1.5"	
				Section Modulus		Coeff. of Stress Csm	Moment of Inertia		Section Modulus		Coeff. of Stress Css	Moment of Inertia		EXT	INT			
				Sm	In3		Im	In4	Ss	In3		Is	In4					
24	0.024	1.380	1.47	0.1352		2677	0.1201		0.1331		2635	0.129		10470	0.48	0.92		
22	0.030	1.650	1.48	0.1832		3627	0.1594		0.1801		3566	0.1695		13900	0.75	1.42		
20	0.036	1.990	1.49	0.2231		4417	0.1982		0.2292		4538	0.2031		17286	1.08	2.03		

Specified Load Tables - psf

Span Ft.	ONE SPAN								TWO EQUAL SPANS								THREE EQUAL SPANS							
	0.024		0.030		0.036		0.024		0.030		0.036		0.024		0.030		0.036							
	A	B	A	B	A	B	A	B	A	B	A	B	A	B	A	B	A	B						
4.0			112	*	151	*	184	*			110	*	149	*	189	*			137	*	186	*	236	*
4.5			88	*	119	*	145	*			87	*	117	*	149	*			108	*	147	*	187	*
5.0			71	*	97	*	118	*			70	*	95	*	121	*			88	*	119	*	151	*
5.5			59	*	80	*	97	*			58	*	79	*	100	*			73	*	98	*	125	*
6.0			50	48	67	64	82	80			49	*	66	*	84	*			61	*	83	*	105	*
6.5			42	38	57	51	70	63			42	*	56	*	72	*			52	*	70	*	90	*
7.0			36	31	49	41	60	50			36	*	49	*	62	*			45	*	61	*	77	*
7.5			32	25	43	33	52	41			31	*	42	*	54	*			39	*	53	*	67	*
8.0			28	20	38	27	46	34			27	*	37	*	47	*			34	*	46	*	59	*
8.5			25	17	33	23	41	28			24	*	33	*	42	*			30	*	41	*	52	53
9.0			22	14	30	19	36	24			22	*	29	*	37	*			27	27	37	36	47	45
9.5			20	12	27	16	33	20			19	*	26	*	34	*			24	23	33	31	42	38

Mercury CL 900 Load Table Notes

- 1) Column 'A' - Loads based on stress. Column 'B' - Loads based on L / 180 deflection. (*) denotes stress governs.
- 2) Table lists lower value of bending or bearing resistance. *italic* denotes web crippling governs.
- 3) For deflection loads other than L / 180 multiply column 'B' by the following factors:

DEFLECTION	MULTIPLIER
L / 240	0.75
L / 360	0.5

- 4) Load tables based on use of A653 Structural Quality Steel Sheet Grade 33 (maximum stress 29.7 Ksi).
- 5) Also available in 0.048 and 0.060 inch. See RD-900

MERCURY METALS

Metric - L.S.D. S136-94

Mercury CL 900

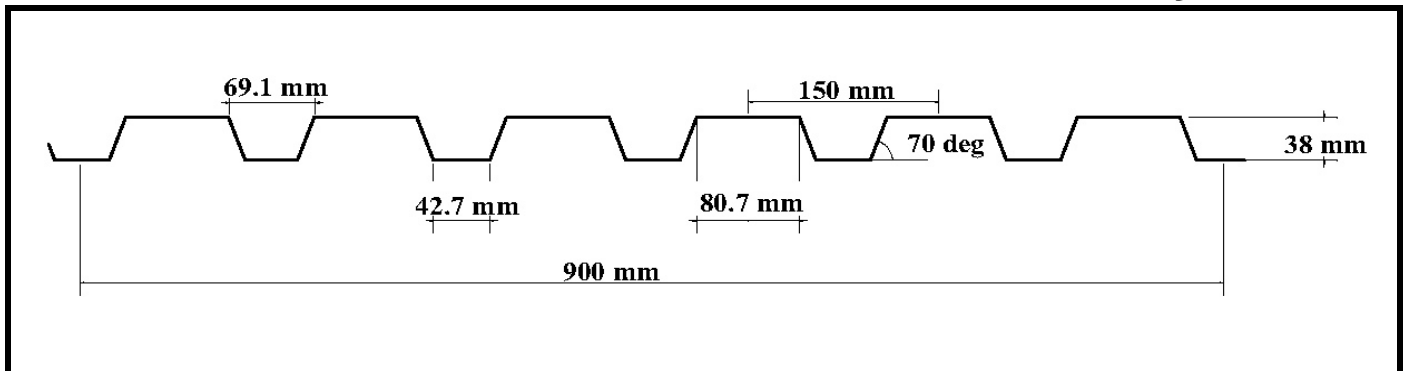

Properties for Mercury CL 900

(Per meter width)

Gauge Number	Base Steel Nominal Thickness mm	Weight Kpa	Overall Depth Dd mm	MID - SPAN			SUPPORT			Coeff. of Deflect. L / 180	Bearing Resist. for 38 mm	
				Section Modulus Sm mm ³	Coeff. of Stress Csm	Moment of Inertia Im mm ⁴	Section Modulus Ss mm ³	Coeff. of Stress Css	Moment of Inertia Is mm ⁴		EXT	INT
24	0.61	0.0660	36.9	7.248	12.0027	163.7	7.138	11.8205	175.9	14.18	7.11	13.7
22	0.76	0.0789	37.1	9.841	16.2967	217.3	9.660	15.9970	231.1	18.82	11.1	21.1
20	0.91	0.0952	37.2	11.987	19.8505	270.5	12.296	20.3622	277.3	23.43	16.1	30.2

Specified Load Tables - Kpa (Kn/m²)

Span M.	ONE SPAN								TWO EQUAL SPANS								THREE EQUAL SPANS							
	0.61		0.76		0.91		0.61		0.76		0.91		0.61		0.76		0.91							
	A	B	A	B	A	B	A	B	A	B	A	B	A	B	A	B	A	B						
1.2	5.6	*	7.5	*	9.2	*			5.5	*	7.4	*	9.4	*			6.8	*	9.3	*	11.8	*		
1.4	4.1	*	5.5	*	6.8	*			4.0	*	5.4	*	6.9	*			5.0	*	6.8	*	8.7	*		
1.6	3.1	*	4.2	*	5.2	*			3.1	*	4.2	*	5.3	*			3.8	*	5.2	*	6.6	*		
1.8	2.5	2.4	3.4	3.2	4.1	4.0			2.4	*	3.3	*	4.2	*			3.0	*	4.1	*	5.2	*		
2.0	2.0	1.8	2.7	2.4	3.3	2.9			2.0	*	2.7	*	3.4	*			2.5	*	3.3	*	4.2	*		
2.2	1.7	1.3	2.2	1.8	2.7	2.2			1.6	*	2.2	*	2.8	*			2.0	*	2.8	*	3.5	*		
2.4	1.4	1.0	1.9	1.4	2.3	1.7			1.4	*	1.9	*	2.4	*			1.7	*	2.3	*	2.9	*		
2.6	1.2	0.8	1.6	1.1	2.0	1.3			1.2	*	1.6	*	2.0	*			1.5	1.5	2.0	2.0	2.5	2.5		
2.8	1.0	0.6	1.4	0.9	1.7	1.1			1.0	*	1.4	*	1.7	*			1.3	1.2	1.7	1.6	2.2	2.0		
3.0	0.9	0.5	1.2	0.7	1.5	0.9			0.9	*	1.2	*	1.5	*			1.1	1.0	1.5	1.3	1.9	1.6		
3.2	0.8	0.4	1.1	0.6	1.3	0.7			0.8	*	1.0	*	1.3	*			1.0	0.8	1.3	1.1	1.7	1.4		
3.4	0.7	0.4	0.9	0.5	1.1	0.6			0.7	*	0.9	*	1.2	*			0.9	0.7	1.2	0.9	1.5	1.1		

Mercury CL 900 Load Table Notes

- 1) Column 'A' - Loads based on stress. Column 'B' - Loads based on L / 180 deflection. (*) denotes stress governs.
- 2) Table lists lower value of bending or bearing resistance. *Italic* denotes web crippling governs.
- 3) For deflection loads other than L / 180 multiply column 'B' by the following factors:

DEFLECTION	MULTIPLIER
L / 240	0.75
L / 360	0.5

- 4) Load tables based on use of A653M Structural Quality Steel Sheet Grade 230 (maximum stress 207 Mpa).
- 5) Also available in 1.22 and 1.52 mm. See RD-900

03/00

MERCURY METALS

Imperial - L.S.D. S136-94

Mercury CL 600

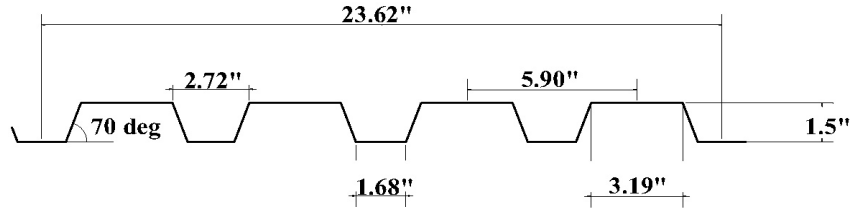

Properties for Mercury CL 600

(Per foot width)

Gauge Number	Base Steel Nominal Thickness	Weight	Overall Depth Dd	MID - SPAN					SUPPORT					Coeff. of Deflect. L / 180	Bearing Resis.1.5" K / FT.	
				Section Modulus		Coeff. of Stress	Moment of Inertia		Section Modulus		Coeff. of Stress	Moment of Inertia			EXT	INT
	Inches	PSF	Inches	Sm	In3	Csm	Im	In4	Ss	In3	Css	Is	In4			
26	0.018	1.310	1.43	0.1116		2210	0.1003	0.1109		2196	0.1092		8749	0.36	0.71	
24	0.024	1.480	1.43	0.1352		2677	0.1201	0.1331		2635	0.129		10470	0.48	0.92	
22	0.030	1.810	1.43	0.1832		3627	0.1594	0.1801		3566	0.1695		13900	0.75	1.42	
20	0.036	2.130	1.43	0.2231		4417	0.1982	0.2292		4538	0.2031		17286	1.08	2.03	

Specified Load Tables - psf

Span Ft.	ONE SPAN								TWO EQUAL SPANS								THREE EQUAL SPANS							
	0.018		0.024		0.030		0.036		0.018		0.024		0.030		0.036		0.018		0.024		0.030		0.036	
	A	B	A	B	A	B	A	B	A	B	A	B	A	B	A	B	A	B	A	B	A	B	A	B
4.0	92	*	112	*	151	*	184	*	92	*	110	*	149	*	189	*	114	*	137	*	186	*	236	*
4.5	73	*	88	*	119	*	145	*	72	*	87	*	117	*	149	*	90	*	108	*	147	*	187	*
5.0	59	*	71	*	97	*	118	*	59	*	70	*	95	*	121	*	73	*	88	*	119	*	151	*
5.5	49	*	59	*	80	*	97	*	48	*	58	*	79	*	100	*	60	*	73	*	98	*	125	*
6.0	41	41	50	48	67	64	82	80	41	*	49	*	66	*	84	*	51	*	61	*	83	*	105	*
6.5	35	32	42	38	57	51	70	63	35	*	42	*	56	*	72	*	43	*	52	*	70	*	90	*
7.0	30	26	36	31	49	41	60	50	30	*	36	*	49	*	62	*	37	*	45	*	61	*	77	*
7.5	26	21	32	25	43	33	52	41	26	*	31	*	42	*	54	*	33	*	39	*	53	*	67	*
8.0	23	17	28	20	38	27	46	34	23	*	27	*	37	*	47	*	29	*	34	*	46	*	59	*
8.5	20	14	25	17	33	23	41	28	20	*	24	*	33	*	42	*	25	*	30	*	41	*	52	*
9.0	18	12	22	14	30	19	36	24	18	*	22	*	29	*	37	*	23	23	27	27	37	36	47	45
9.5	16	10	20	12	27	16	33	20	16	*	19	*	26	*	34	*	20	19	24	23	33	31	42	38

Mercury CL 600 Load Table Notes

- Column 'A' - Loads based on stress. Column 'B' - Loads based on L / 180 deflection. (*) denotes
- Table lists lower value of bending or bearing resistance. *Italic* denotes web crippling govns.
- For deflection loads other than L / 180 multiply column 'B' by the following factors:

<u>DEFLECTION</u>	<u>MULTIPLIER</u>
L / 240	0.75
L / 360	0.5
- Load tables based on use of A653 Structural Quality Steel Sheet Grade 33 (maximum stress 29.7 Ksi).
- Also available in 0.048 and 0.060 inch. See RD-900

MERCURY METALS

Metric - L.S.D. S136-94

Mercury CL 600

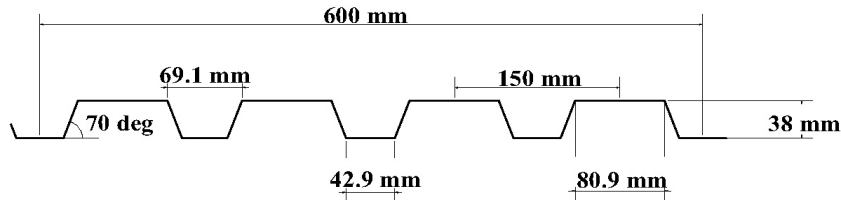

Properties for Mercury CL 600

(Per meter width)

Gauge Number	Base Steel Nominal Thickness mm	Weight Kpa	Overall Depth Dd mm	MID - SPAN				SUPPORT				Coeff. of Deflect. L / 180	Bearing Resist. for 38 mm			
				Section Modulus		Coeff. of Stress Csm	Moment of Inertia		Section Modulus		Coeff. of Stress Css		Moment of Inertia		EXT	INT
				Sm	mm ³		Im	mm ⁴	Ss	mm ³			Is	mm ⁴		
26	0.46	0.0550	36.8	5.985	9.9112	136.6	5.948	9.8499	148.8	11.83	5.43	10.5				
24	0.61	0.0660	36.9	7.248	12.0027	163.7	7.138	11.8205	175.9	14.18	7.11	13.7				
22	0.76	0.0789	37.1	9.841	16.2967	217.3	9.660	15.9970	231.1	18.82	11.1	21.1				
20	0.91	0.0952	37.2	11.987	19.8505	270.5	12.296	20.3622	277.3	23.43	16.1	30.2				

Specified Load Tables - Kpa (Kn/m²)

Span M.	ONE SPAN								TWO EQUAL SPANS								THREE EQUAL SPANS							
	0.46		0.61		0.76		0.91		0.46		0.61		0.76		0.91		0.46		0.61		0.76		0.91	
	A	B	A	B	A	B	A	B	A	B	A	B	A	B	A	B	A	B	A	B	A	B	A	B
1.2	4.6	*	5.6	*	7.5	*	9.2	*	4.6	*	5.5	*	7.4	*	9.4	*	5.7	*	6.8	*	9.3	*	11.8	*
1.4	3.4	*	4.1	*	5.5	*	6.8	*	3.4	*	4.0	*	5.4	*	6.9	*	4.2	*	5.0	*	6.8	*	8.7	*
1.6	2.6	*	3.1	*	4.2	*	5.2	*	2.6	*	3.1	*	4.2	*	5.3	*	3.2	*	3.8	*	5.2	*	6.6	*
1.8	2.0	2.0	2.5	2.4	3.4	3.2	4.1	4.0	2.0	*	2.4	*	3.3	*	4.2	*	2.5	*	3.0	*	4.1	*	5.2	*
2.0	1.7	1.5	2.0	1.8	2.7	2.4	3.3	2.9	1.6	*	2.0	*	2.7	*	3.4	*	2.1	*	2.5	*	3.3	*	4.2	*
2.2	1.4	1.1	1.7	1.3	2.2	1.8	2.7	2.2	1.4	*	1.6	*	2.2	*	2.8	*	1.7	*	2.0	*	2.8	*	3.5	*
2.4	1.1	0.9	1.4	1.0	1.9	1.4	2.3	1.7	1.1	*	1.4	*	1.9	*	2.4	*	1.4	*	1.7	*	2.3	*	2.9	*
2.6	1.0	0.7	1.2	0.8	1.6	1.1	2.0	1.3	1.0	*	1.2	*	1.6	*	2.0	*	1.2	*	1.5	1.5	2.0	2.0	2.5	2.5
2.8	0.8	0.5	1.0	0.6	1.4	0.9	1.7	1.1	0.8	*	1.0	*	1.4	*	1.7	*	1.0	1.0	1.3	1.2	1.7	1.6	2.2	2.0
3.0	0.7	0.4	0.9	0.5	1.2	0.7	1.5	0.9	0.7	*	0.9	*	1.2	*	1.5	*	0.9	0.8	1.1	1.0	1.5	1.3	1.9	1.6
3.2	0.6	0.4	0.8	0.4	1.1	0.6	1.3	0.7	0.6	*	0.8	*	1.0	*	1.3	*	0.8	0.7	1.0	0.8	1.3	1.1	1.7	1.4
3.4	0.6	0.3	0.7	0.4	0.9	0.5	1.1	0.6	0.6	*	0.7	*	0.9	*	1.2	*	0.7	0.6	0.9	0.7	1.2	0.9	1.5	1.1

Mercury CL 600 Load Table Notes

- Column 'A' - Loads based on stress. Column 'B' - Loads based on L / 180 deflection. (*) denotes stress governs.
- Table lists lower value of bending or bearing resistance. *Italic* denotes web crippling governs.
- For deflection loads other than L / 180 multiply column 'B' by the following factors:

DEFLECTION	MULTIPLIER
L / 240	0.75
L / 360	0.5

- Load tables based on use of A653M Structural Quality Steel Sheet Grade 230 (maximum stress 207 Mpa).
- Also available in 1.22 and 1.52 mm. See RD-900.

MERCURY METALS

Imperial - L.S.D. S136-94

Mercury CL 912

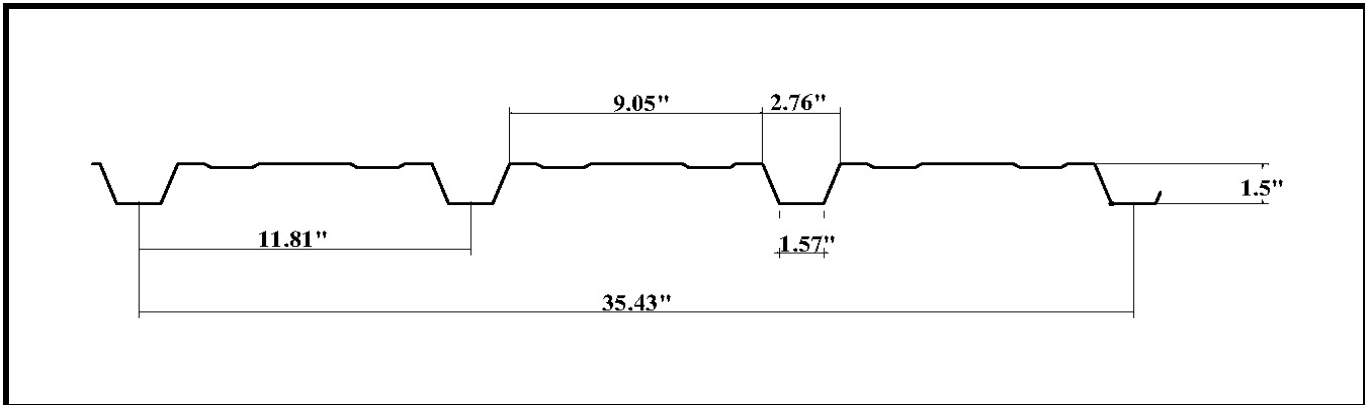

Properties for Mercury CL 912 (Per foot width)

Gauge Number	Base Steel Nominal Thickness Inches	Weight PSF	Overall Depth Inches	MID - SPAN						SUPPORT						Coeff. of Deflect. L / 180	Bearing Resis.1.5\"	
				Section Modulus		Coeff. of Stress Csm	Moment of Inertia		Section Modulus		Coeff. of Stress Css	Moment of Inertia		EXT	INT			
				Sm	In3		Im	In4	Ss	In3		Is	In4					
26	0.018	1.090	1.46	0.0576	1141	0.0523	0.0605	1198	0.0756	4565	0.18	0.35						
24	0.024	1.300	1.47	0.0702	1390	0.0651	0.0726	1438	0.0899	5679	0.24	0.46						
22	0.030	1.570	1.48	0.0922	1826	0.0951	0.0981	1942	0.1189	8290	0.37	0.71						
20	0.036	1.880	1.49	0.1128	2233	0.1305	0.1247	2469	0.1424	11385	0.54	1.02						

Specified Load Tables - psf

Span Ft.	ONE SPAN								TWO EQUAL SPANS								THREE EQUAL SPANS							
	0.018		0.024		0.030		0.036		0.018		0.024		0.030		0.036		0.018		0.024		0.030		0.036	
	A	B	A	B	A	B	A	B	A	B	A	B	A	B	A	B	A	B	A	B	A	B	A	B
4.0	48	*	58	*	76	*	93	*	50	*	60	*	81	*	103	*	59	*	75	*	101	*	129	*
4.5	38	*	46	*	60	*	74	*	39	*	47	*	64	*	81	*	49	*	59	*	80	*	102	*
5.0	30	*	37	*	49	*	60	*	32	*	38	*	52	*	66	*	40	47	48	*	65	*	82	*
5.5	25	*	31	*	40	*	49	*	26	*	32	*	43	*	54	*	33	43	40	*	54	*	68	*
6.0	21	21	26	26	34	*	41	*	22	*	27	*	36	*	46	*	28	39	33	*	45	*	57	*
6.5	18	17	22	21	29	*	35	*	19	*	23	*	31	*	39	*	24	31	28	*	38	*	49	*
7.0	16	13	19	17	25	24	30	*	16	*	20	*	26	*	34	*	20	25	24	*	33	*	42	*
7.5	14	11	16	13	22	20	26	*	14	*	17	*	23	*	29	*	18	20	21	*	29	*	37	*
8.0	12	9	14	11	19	16	23	22	12	*	15	*	20	*	26	*	16	17	19	*	25	*	32	*
8.5	11	7	13	9	17	13	21	19	11	*	13	*	18	*	23	*	14	14	17	17	22	*	28	*
9.0	9	6	11	8	15	11	18	16	10	*	12	*	16	*	20	*	12	12	15	15	20	*	25	*
9.5	8	5	10	7	13	10	16	13	9	*	11	*	14	*	18	*	11	10	13	13	18	18	23	*

Mercury CL 912 Load Table Notes

- 1) Column 'A' - Loads based on stress. Column 'B' - Loads based on L / 180 deflection. (*) denotes stress governs.
- 2) Table lists lower value of bending or bearing resistance. *Italic* denotes web crippling governs.
- 3) For deflection loads other than L / 180 multiply column 'B' by the following factors:

<u>DEFLECTION</u>	<u>MULTIPLIER</u>
L / 240	0.75
L / 360	0.5
- 4) Load tables based on use of A653 Structural Quality Steel Sheet Grade 33 (maximum stress 29.7 Ksi).

MERCURY METALS

Metric - L.S.D. S136-94

Mercury CL 912

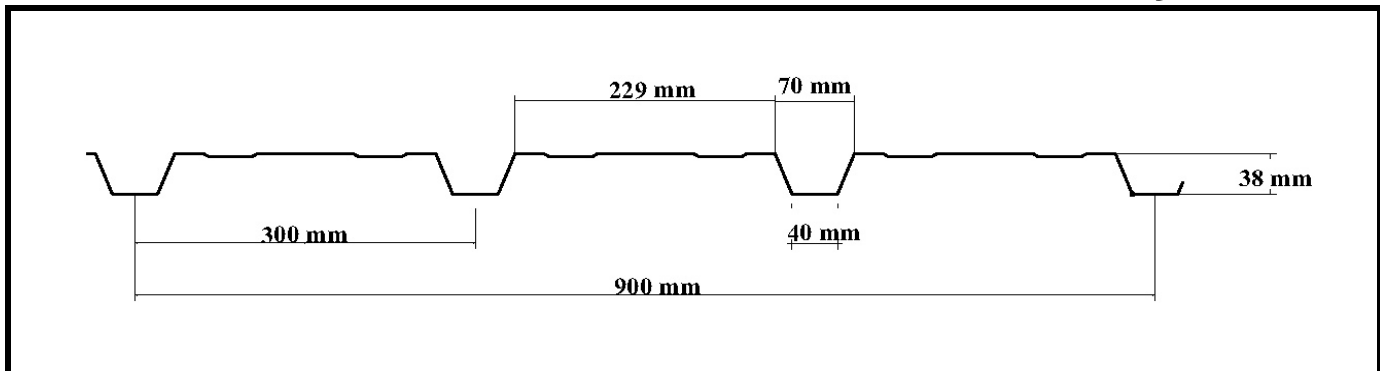

Properties for Mercury CL 912 (Per meter width)

Gauge Number	Base Steel Nominal Thickness	Weight	Overall Depth	MID - SPAN				SUPPORT				Coeff. of Deflect. L/ 180	Bearing Resist. for 38 mm		
				Section Modulus	Coeff. of Stress	Moment of Inertia		Section Modulus	Coeff. of Stress	Moment of Inertia			EXT	INT	
	mm	Kpa	mm	Sm	mm ³	Csm	Im	mm ⁴	Ss	mm ³	Css	Is	mm ⁴		
				x10 ³		x10 ³	x10 ³	x10 ³		x10 ³					
26	0.46	0.0522	36.8	3.096	5.1270	71.5	3.252	5.3850	1.033	6.19	2.66	5.14			
24	0.61	0.0622	36.9	3.774	6.2497	88.9	3.903	6.4636	1.228	7.70	3.41	6.68			
22	0.76	0.0751	37.1	4.957	8.2086	129.8	5.274	8.7339	1.623	11.02	5.46	10.3			
20	0.91	0.0900	37.2	6.064	10.0043	178.3	6.704	11.1022	1.944	15.44	7.88	14.8			

Specified Load Tables - Kpa (Kn/m²)

Span M.	ONE SPAN								TWO EQUAL SPANS								THREE EQUAL SPANS							
	0.46		0.61		0.76		0.91		0.46		0.61		0.76		0.91		0.46		0.61		0.76		0.91	
	A	B	A	B	A	B	A	B	A	B	A	B	A	B	A	B	A	B	A	B	A	B	A	B
1.2	2.4	*	2.9	*	3.8	*	4.6	*	2.5	*	3.0	*	4.0	*	5.1	*	2.9	*	3.7	*	5.1	*	6.4	*
1.4	1.7	*	2.1	*	2.8	*	3.4	*	1.8	*	2.2	*	3.0	*	3.8	*	2.3	*	2.7	*	3.7	*	4.7	*
1.6	1.3	*	1.6	*	2.1	*	2.6	*	1.4	*	1.7	*	2.3	*	2.9	*	1.8	*	2.1	*	2.8	*	3.6	*
1.8	1.1	1.1	1.3	1.3	1.7	*	2.1	*	1.1	*	1.3	*	1.8	*	2.3	*	1.4	*	1.7	*	2.2	*	2.9	*
2.0	0.9	0.8	1.0	1.0	1.4	1.4	1.7	*	0.9	*	1.1	*	1.5	*	1.9	*	1.1	*	1.3	*	1.8	*	2.3	*
2.2	0.7	0.6	0.9	0.7	1.1	1.0	1.4	*	0.7	*	0.9	*	1.2	*	1.5	*	0.9	*	1.1	*	1.5	*	1.9	*
2.4	0.6	0.4	0.7	0.6	1.0	0.8	1.2	1.1	0.6	*	0.7	*	1.0	*	1.3	*	0.8	0.8	0.9	*	1.3	*	1.6	*
2.6	0.5	0.4	0.6	0.4	0.8	0.6	1.0	0.9	0.5	*	0.6	*	0.9	*	1.1	*	0.7	0.7	0.8	0.8	1.1	*	1.4	*
2.8	0.4	0.3	0.5	0.4	0.7	0.5	0.9	0.7	0.5	*	0.5	*	0.7	*	0.9	*	0.6	0.5	0.7	0.7	0.9	0.9	1.2	*
3.0	0.4	0.2	0.5	0.3	0.6	0.4	0.7	0.6	0.4	*	0.5	*	0.6	*	0.8	*	0.5	0.4	0.6	0.5	0.8	0.8	1.0	*
3.2	0.3	0.2	0.4	0.2	0.5	0.3	0.7	0.5	0.4	*	0.4	*	0.6	*	0.7	*	0.4	0.4	0.5	0.4	0.7	0.6	0.9	0.9
3.4	0.3	0.2	0.4	0.2	0.5	0.3	0.6	0.4	0.3	*	0.4	*	0.5	*	0.6	*	0.4	0.3	0.5	0.4	0.6	0.5	0.8	0.7

Mercury CL 912 Load Table Notes

- Column 'A' - Loads based on stress. Column 'B' - Loads based on L / 180 deflection. (*) denotes stress governs.
- Table lists lower value of bending or bearing resistance. *Italic* denotes web crippling governs.
- For deflection loads other than L / 180 multiply column 'B' by the following factors:

<u>DEFLECTION</u>	<u>MULTIPLIER</u>
L / 240	0.75
L / 360	0.5
- Load tables based on use of A653M Structural Quality Steel Sheet Grade 230 (maximum stress 207 Mpa).

MERCURY METALS

Imperial - L.S.D

Mercury CL 712

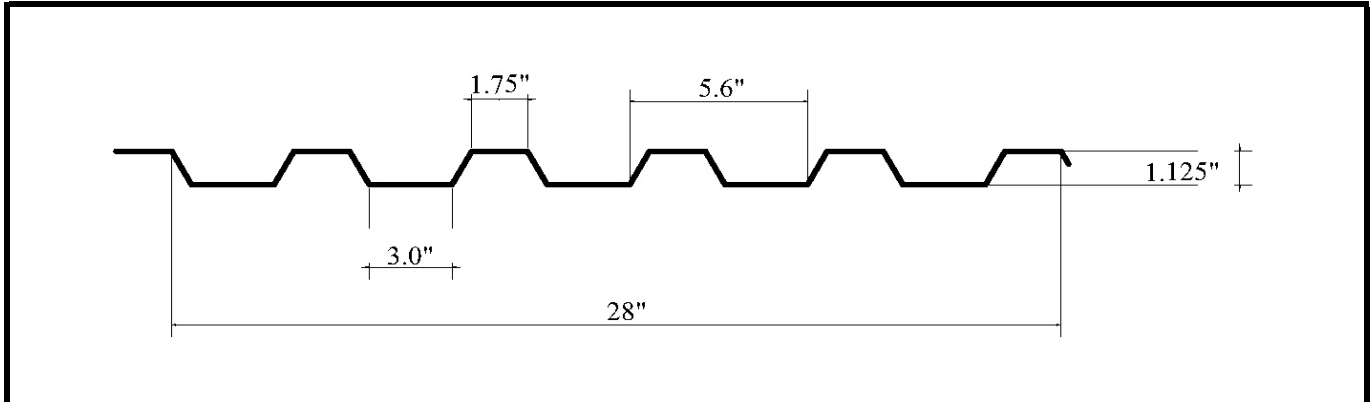

Properties for Mercury CL 712 (Per foot width)

Gauge Number	Base Steel Nominal Thickness Inches	Weight Pounds per Sq Ft.	MID - SPAN						SUPPORT						Coeff. of Defect.		Bear'g Resist1.5" K / ft.		Shear Resist. lb / ft.
			Section Modulus		Coeff. of Stress	Moment of Inertia		Section Modulus		Coeff. of Stress	Moment of Inertia		L / 180	EXT	INT	Φv * Vn			
			Set	In3	Csm	Id	In4	Seb	In3	Css	Id	In4							
26	0.018	0.945	0.0590		1168		0.0421	0.0622		1232		0.0497	3672	0.24	0.48	1395			
24	0.024	1.260	0.0913		1808		0.062	0.0962		1905		0.0738	5407	0.39	0.86	1850			
22	0.030	1.575	0.1294		2562		0.0848	0.1363		2699		0.0963	7396	0.64	1.38	2299			

Allowable Superimposed Load Tables - psf

Span Ft.	ONE SPAN								TWO EQUAL SPANS								THREE EQUAL SPANS							
	0.018		0.024		0.030				0.018		0.024		0.030				0.018		0.024		0.030			
	A	B	A	B	A	B	A	B	A	B	A	B	A	B	A	B	A	B	A	B	A	B	A	B
3.0	87	*	134	*	190	*			91	*	141	*	200	*			106	*	173	*	250	*		
3.5	64	*	98	*	139	*			67	*	104	*	147	*			84	*	130	*	184	*		
4.0	49	*	75	*	107	*			51	*	79	*	112	*			64	*	99	*	141	*		
4.5	38	*	60	59	84	81			41	*	63	*	89	*			51	*	78	*	111	*		
5.0	31	29	48	43	68	59			33	*	51	*	72	*			41	*	63	*	90	*		
5.5	26	22	40	33	56	44			27	*	42	*	59	*			34	*	52	*	74	*		
6.0	22	17	33	25	47	34			23	*	35	*	50	*			29	*	44	*	62	*		
6.5	18	13	29	20	40	27			19	*	30	*	43	*			24	*	38	37	53	51		
7.0	16	11	25	16	35	22			17	*	26	*	37	52			21	20	32	30	46	41		
7.5	14	9	21	13	30	18			15	*	23	*	32	42			18	16	28	24	40	33		
8.0	12	7	19	11	27	14			13	*	20	*	28	35			16	14	25	20	35	27		
8.5	11	6	17	9	24	12			11	*	18	*	25	29			14	11	22	17	31	23		

Mercury CL 712 Load Table Notes

- Column 'A' - Loads based on stress. Column 'B' - Loads based on L / 180 deflection. (*) denotes stress governs.
- Table lists lower value of bending or bearing resistance.
- For deflection loads other than L / 240 multiply column 'B' by the following factors:

<u>DEFLECTION</u>	<u>MULTIPLIER</u>
L / 240	0.75
L / 360	0.5
- Load tables based on use of A653 Structural Quality Steel Sheet Grade 33 (maximum stress 29.7 Ksi).

MERCURY METALS

Metric - L.S.D

Mercury CL 712

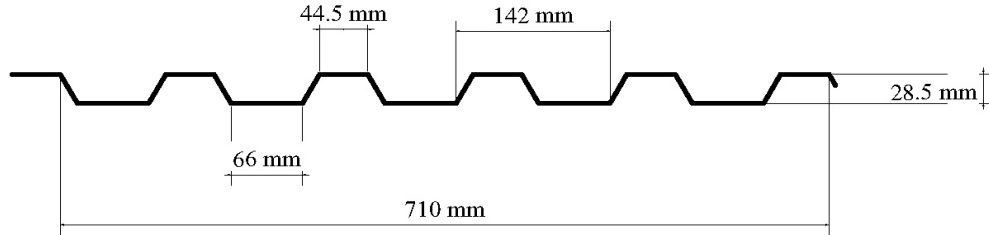

Properties for Mercury CL 712

(Per meter width)

Gauge Number	Base Steel Nominal Thickness mm	Weight Kpa	MID - SPAN			SUPPORT			Coeff. of Deflect. L/180	Bearing Resist. for 76mm		Shear Resist. KN / m Φv * Vn
			Section Modulus Sm mm ³ x10 ⁴	Coeff. of Stress Csm	Moment of Inertia Im mm ⁴ x10 ⁶	Section Modulus Ss mm ³ x10 ⁴	Coeff. of Stress Css	Moment of Inertia Is mm ⁴ x10 ⁶		EXT	INT	
26	0.46	0.0452	0.3172	5.2528	0.0575	0.3344	5.5377	0.0679	4.98	3.48	6.98	20.339
24	0.61	0.0617	0.4909	8.1293	0.0847	0.5127	8.4906	0.1008	7.34	5.64	12.6	26.964
22	0.76	0.0754	0.6957	11.5208	0.1158	0.7328	12.1352	0.1315	10.03	9.27	20.1	33.511

Specified Load Tables - Kpa (Kn/m²)

Spar M.	ONE SPAN								TWO EQUAL SPANS								THREE EQUAL SPANS							
	0.46		0.61		0.76				0.46		0.61		0.76				0.46		0.61		0.76			
	A	B	A	B	A	B	A	B	A	B	A	B	A	B	A	B	A	B	A	B	A	B	A	B
0.6	7.7	*	12.5	*	20.6	*			7.7	*	12.5	*	20.6	*			7.7	*	12.5	*	20.6	*		
0.8	5.5	*	8.5	*	12.0	*			5.8	*	8.8	*	12.6	*			5.8	*	9.4	*	15.4	*		
1.0	3.5	*	5.4	*	7.7	*			3.7	*	5.7	*	8.1	*			4.6	*	7.1	*	10.1	*		
1.2	2.4	*	3.8	*	5.3	*			2.6	*	3.9	*	5.6	*			3.2	*	4.9	*	7.0	*		
1.4	1.8	1.8	2.8	2.7	3.9	3.7			1.9	*	2.9	*	4.1	*			2.4	*	3.6	*	5.2	*		
1.6	1.4	1.2	2.1	1.8	3.0	2.4			1.4	*	2.2	*	3.2	*			1.8	*	2.8	*	4.0	*		
1.8	1.1	0.9	1.7	1.3	2.4	1.7			1.1	*	1.7	*	2.5	*			1.4	*	2.2	*	3.1	*		
2.0	0.9	0.6	1.4	0.9	1.9	1.3			0.9	*	1.4	*	2.0	*			1.2	1.2	1.8	1.7	2.5	2.4		
2.2	0.7	0.5	1.1	0.7	1.6	0.9			0.8	*	1.2	*	1.7	*			1.0	0.9	1.5	1.3	2.1	1.8		
2.4	0.6	0.4	0.9	0.5	1.3	0.7			0.6	*	1.0	*	1.4	*			0.8	0.7	1.2	1.0	1.8	1.4		
2.6	0.5	0.3	0.8	0.4	1.1	0.6			0.5	*	0.8	*	1.2	*			0.7	0.5	1.0	0.8	1.5	1.1		
2.8	0.4	0.2	0.7	0.3	1.0	0.5			0.5	0.5	0.7	*	1.0	*			0.6	0.4	0.9	0.6	1.3	0.9		

Mercury CL 712 Load Table Notes

- Column 'A' - Loads based on stress. Column 'B' - Loads based on L / 180 deflection.
- Table lists lower value of bending or bearing resistance.
- For deflection loads other than L / 180 multiply column 'B' by the following factors:

DEFLECTION	MULTIPLIER
L / 240	0.75
L / 360	0.5

- Load tables based on use of A653M Structural Quality Steel Sheet Grade 230 (maximum stress 207 Mpa).

MERCURY METALS

Imperial - L.S.D. S136-94

Mercury D-306

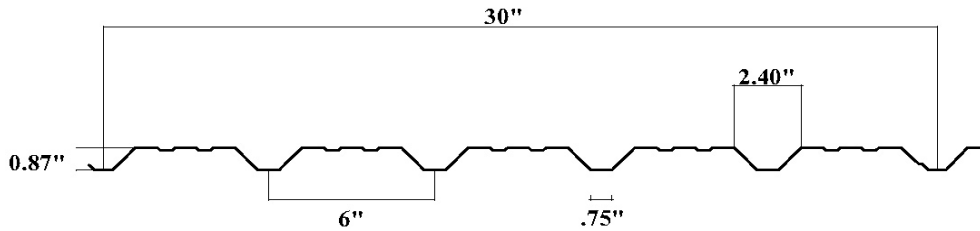

Properties for Mercury D-306

(Per foot width)

Gauge Number	Base Steel Nominal Thickness	Weight	Overall Depth	MID - SPAN					SUPPORT					Coeff. of Deflect.	Bearing Resist. 2"	
				Section Modulus		Coeff. of Stress	Moment of Inertia		Section Modulus		Coeff. of Stress	Moment of Inertia			L / 180	EXT
	Inches	PSF	Inches	Sm	In3	Csm	Im	In4	Ss	In3	Css	Is	In4			
29	0.0135	0.662	0.875	0.0242		479	0.0118	0.0311		616	0.0199		1029	0.17	0.28	
26	0.018	0.882	0.875	0.0359		711	0.0168	0.0430		851	0.0255		1465	0.29	0.51	
24	0.024	1.176	0.875	0.0559		1107	0.0206	0.0560		1109	0.0331		1797	0.47	0.94	
22	0.030	1.470	0.875	0.0710		1406	0.0306	0.0687		1360	0.0405		2667	0.69	1.49	

Specified Load Tables - psf

Span Ft.	ONE SPAN								TWO EQUAL SPANS								THREE EQUAL SPANS							
	0.0135		0.018		0.024		0.030		0.0135		0.018		0.024		0.030		0.0135		0.018		0.024		0.030	
	A	B	A	B	A	B	A	B	A	B	A	B	A	B	A	B	A	B	A	B	A	B	A	B
1.5	142	*	211	*	328	*	417	*	122	*	228	*	329	*	403	*	122	*	228	*	411	*	504	*
2.0	80	*	119	*	185	*	234	*	92	*	142	*	185	*	227	*	92	*	171	*	231	*	283	*
2.5	51	*	76	*	118	115	150	*	66	*	91	*	118	*	145	*	73	*	114	*	148	*	181	*
3.0	35	*	53	*	82	67	104	99	46	*	63	*	82	*	101	*	55	*	79	*	103	*	126	*
3.5	26	24	39	34	60	42	77	62	34	*	46	*	60	*	74	*	41	*	58	*	75	*	93	*
4.0	20	16	30	23	46	28	59	42	26	*	35	*	46	*	57	*	31	30	44	43	58	53	71	*
4.5	16	11	23	16	36	20	46	29	20	*	28	*	37	*	45	*	25	21	35	30	46	37	56	55
5.0	13	8	19	12	30	14	37	21	16	*	23	*	30	*	36	*	20	16	28	22	37	27	45	40
5.5	11	6	16	9	24	11	31	16	14	*	19	*	24	*	30	*	16	12	23	17	31	20	37	30
6.0	9	5	13	7	21	8	26	12	11	11	16	*	21	20	25	*	14	9	20	13	26	16	31	23
6.5	8	4	11	5	17	7	22	10	10	9	13	13	17	16	21	*	12	7	17	10	22	12	27	18
7.0	7	3	10	4	15	5	19	8	8	7	12	10	15	13	19	19	10	6	14	8	19	10	23	15

Mercury D-306 Load Table Notes

- 1) Column 'A' - Loads based on stress. Column 'B' - Loads based on L / 180 deflection. (*) denotes stress governs.
- 2) Table lists lower value of bending or bearing resistance. *Italic* denotes web crippling governs.
- 3) For deflection loads other than L / 180 multiply column 'B' by the following factors:

<u>DEFLECTION</u>	<u>MULTIPLIER</u>
L / 240	0.75
L / 360	0.5
- 4) Load tables based on use of A653 Structural Quality Steel Sheet Grade 33 (maximum stress 29.7 Ksi).

MERCURY METALS

Metric - L.S.D. S136-94

Mercury D-306

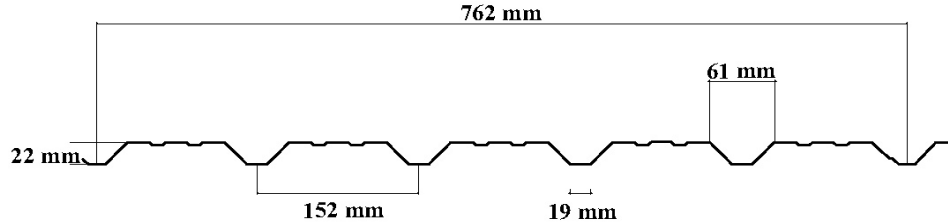

Properties for Mercury D-306

(Per meter width)

Gauge Number	Base Steel Nominal Thickness	Weight	Overall Depth	MID - SPAN			SUPPORT			Coeff. of Deflect.	Bearing Resist.	
				Section Modulus	Coeff. of Stress	Moment of Inertia	Section Modulus	Coeff. of Stress	Moment of Inertia		for 50 mm	
	mm	Kpa	mm	Sm	Csm	Im	Ss	Css	Is	L/180	EXT	INT
29	0.34	0.0317	22.2	1.302	2.1561	16.1	1.669	2.7639	26.0	1.3931	2.54	4.02
26	0.46	0.0422	22.2	1.930	3.1961	23.0	2.311	3.8270	34.8	1.9917	4.16	7.48
24	0.61	0.0563	22.2	3.005	4.0768	26.8	3.011	4.9862	45.3	2.3203	6.83	13.7
22	0.76	0.0704	22.2	3.816	6.3193	41.8	3.691	6.1123	55.2	3.6238	10.0	21.8

Specified Load Tables - Kpa (Kn/m²)

Span M.	ONE SPAN								TWO EQUAL SPANS								THREE EQUAL SPANS							
	0.34		0.46		0.61		0.76		0.34		0.46		0.61		0.76		0.34		0.46		0.61		0.76	
	A	B	A	B	A	B	A	B	A	B	A	B	A	B	A	B	A	B	A	B	A	B	A	B
0.4	8.5	*	13	*	17.0	*	26.3	*	6.7	*	12	*	20.8	*	25.5	*	6.7	*	12	*	22.8	*	31.8	*
0.6	4.0	*	5.9	*	7.5	*	11.7	*	4.5	*	7.1	*	9.2	*	11.3	*	4.5	*	8.3	*	11.5	*	14.1	*
0.8	2.2	*	3.3	*	4.2	*	6.6	*	2.9	*	4.0	*	5.2	*	6.4	*	3.4	*	5.0	*	6.5	*	8.0	*
1.0	1.4	1.4	2.1	2.0	2.7	2.3	4.2	3.6	1.8	*	2.6	*	3.3	*	4.1	*	2.2	*	3.2	*	4.2	*	5.1	*
1.2	1.0	0.8	1.5	1.2	1.9	1.3	2.9	2.1	1.3	*	1.8	*	2.3	*	2.8	*	1.6	1.5	2.2	2.2	2.9	2.5	3.5	*
1.4	0.7	0.5	1.1	0.7	1.4	0.8	2.1	1.3	0.9	*	1.3	*	1.7	*	2.1	*	1.1	1.0	1.6	1.4	2.1	1.6	2.6	2.5
1.6	0.6	0.3	0.8	0.5	1.1	0.6	1.6	0.9	0.7	*	1.0	*	1.3	*	1.6	*	0.9	0.6	1.2	0.9	1.6	1.1	2.0	1.7
1.8	0.4	0.2	0.7	0.3	0.8	0.4	1.3	0.6	0.6	0.6	0.8	*	1.0	1.0	1.3	*	0.7	0.5	1.0	0.6	1.3	0.8	1.6	1.2
2.0	0.4	0.2	0.5	0.2	0.7	0.3	1.1	0.5	0.5	0.4	0.6	0.6	0.8	0.7	1.0	*	0.6	0.3	0.8	0.5	1.0	0.5	1.3	0.9
2.2	0.3	0.1	0.4	0.2	0.6	0.2	0.9	0.3	0.4	0.3	0.5	0.4	0.7	0.5	0.8	0.8	0.5	0.2	0.7	0.4	0.9	0.4	1.1	0.6
2.4	0.2	0.1	0.4	0.1	0.5	0.2	0.7	0.3	0.3	0.2	0.4	0.3	0.6	0.4	0.7	0.6	0.4	0.2	0.6	0.3	0.7	0.3	0.9	0.5
2.6	0.2	0.1	0.3	0.1	0.4	0.1	0.6	0.2	0.3	0.2	0.4	0.3	0.5	0.3	0.6	0.5	0.3	0.1	0.5	0.2	0.6	0.2	0.8	0.4

Mercury D-306 Load Table Notes

- Column 'A' - Loads based on stress. Column 'B' - Loads based on L / 180 deflection. (*) denotes stress governs.
- Table lists lower value of bending or bearing resistance. *Italic* denotes web crippling governs.
- For deflection loads other than L / 180 multiply column 'B' by the following factors:

<u>DEFLECTION</u>	<u>MULTIPLIER</u>
L / 240	0.75
L / 360	0.5
- Load tables based on use of A653M Structural Quality Steel Sheet Grade 230 (maximum stress 207 Mpa).

MERCURY METALS

Metric / Imperial- L.S.D. S136-94

Mercury L 335 LINER

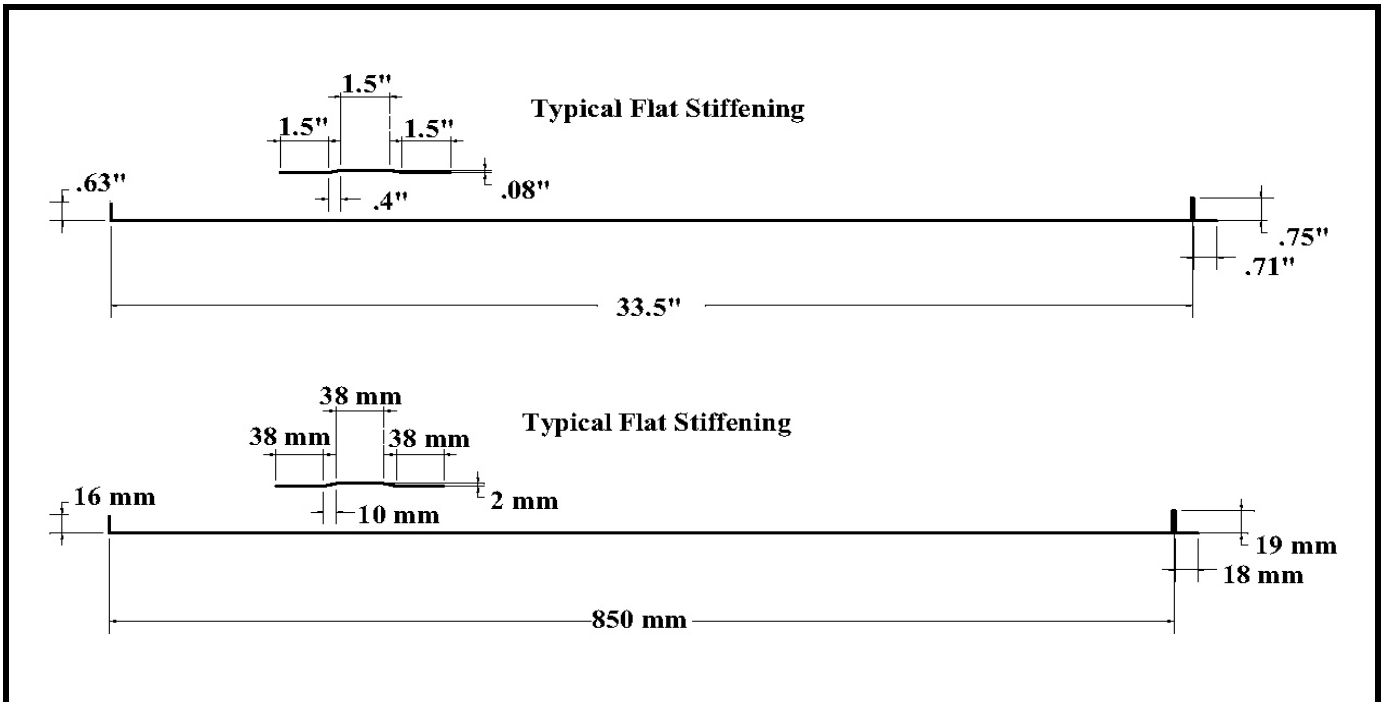

Properties for Mercury L 335 (Per meter or foot width)

Gauge Number	METRIC				IMPERIAL				Material Availability
	Base Steel Nominal Thickness	Weight	Overall Depth	Maximum Suggested Liner Length	Base Steel Nominal Thickness	Weight	Overall Depth	Maximum Suggested Liner Length	
	mm	Kpa	mm	mm	in	psf	in	ft	
26	0.46	0.0378	19	7300	0.018	0.7900	0.75	24' - 0"	Z275 AZ 180 Prepainted
24	0.61	0.0504	19	9150	0.024	1.0530	0.75	30' - 0"	
22	0.76	0.0630	19	9150	0.030	1.3160	0.75	30' - 0"	
20	0.91	0.0756	19	9150	0.036	1.5800	0.75	30' - 0"	

METAL SANDWICH PANELS:

The L 335 panel is a liner panel with nominal structural properties to be used in combination with exterior roof cladding, wall cladding and/or standing seam roof system panels to form a proper sandwich panel roof or wall system. "Z"-bars and L 335 Liner panel are fastened directly to the exterior flange of the structural girts or purlins, leaving the full wind loads to be born by the strong, profiled, exterior panel, transferring those forces through the subgirt to the structural girt or purlin. The desired insulation thickness is encapsulated between the liner sheet and the exterior structural sheet to provide thermal efficiency. Through proper detailing, the flute cavity behind the exterior panel is vented to the exterior, for pressure equalization, thereby creating a true rain screen wall or roof assembly.

LINER SHEET:

The liner panel provides a hard, finished, architectural surface which acts as an excellent vapour barrier to prevent the migration of moisture from the warm interior into the insulation, and an air barrier to resist exterior air entry into the building interior. To function to it's best capability, the steel liner must be sealed with a continuous bead of caulking applied to the sidelaps, and top and bottom joints at the roof and floor interfaces.

MERCURY METALS

Metric / Imperial- L.S.D. S136-94

Mercury L 335 LINER

SUBGIRTS:

The subgirts are the structural connection between the exterior wind bearing panel and the structural girt or purlin. In addition, the subgirts subdivide the insulation cavity, providing support to the installation batts, and forms compartments to restrict rapid air movement between zones of different air pressures prevalent in rain screen systems. Thermal bridging is not a problem in most buildings. However, by the application of insulating tape to the flanges of the subgirts or the use of proprietary thermal subgirt systems thermal bridging problems may be resolved.

INSULATION:

The insulation best suited for the metal sandwich panel is a semi - rigid fiberglass batt with a density of 1.1 to 3.5 pcf which will fill the panel cavity better than more rigid insulation such as expanded or isocyanurate foam boards. The exception to this statement is the use of a bearing foam or isocyanurate insulation used in Mercury's Rib Roof roof system. Please contact your Mercury Metals Representative for details. An additional air barrier may be placed over the exterior face of the insulation prior to placement of the exterior panel to resist excessive venting of the fiberglass insulation during windy weather.

INSULATION VALUES FOR AF-110 FIBERGLASS INSULATION (1.10 pcf density)

SI METRIC		IMPERIAL	
Thickness mm	"RSI" VALUE M ² °C / W	Thickness inches	R VALUE Ft ² Hr °F / Btu
38	1.0	1.5	5.7
51	1.3	2	7.6
76	2.0	3	11.4
102	2.7	4	15.2
127	3.3	5	19.0
152	4.0	6	22.8

The actual "RSI" or "R" value of the final panel assembly will vary with the type of panel assembly used.

EXTERIOR PANELS:

Subject to the structural girt or purlin spacing, the applied wind or roof live loads any of the Mercury Wall Clad, Roof Clad or Standing Seam Roof Systems profiles may be used as the exterior sheet. It is important not to use a Wall Clad Profile for a roof application. CSSBI defines roof applications as any material laid more that 20 degrees from the vertical. In addition to the aesthetics, care should be given to the choice of finish and it's ability to resist the prevailing atmospheric conditions. The following CSSBI design aids are available to assist in the proper design, detailing and material selection for roof, wall and standing seam roof systems. Please contact your Mercury Metals representative for assistance.

- CSSBI - Insulated Sheet Steel Wall Assemblies
- CSSBI - Thermal Resistance of Double Skin Insulated Sheet Steel Walls & Roofs
- CSSBI - Criteria for the Design and Installation of Double Skin Insulated Steel Roofs
- CSSBI - Roofing and Flashing Problems
- CSSBI - Cost Considerations for Prepainted Sheet Steel Cladding
- CSSBI - Prefinished Sheet Steel for Building Construction
- CSSBI - Care and Maintenance of Prefinished Sheet Steel Building Products
- CSSBI - Repainting Factory Prefinished Metal Panels

MERCURY METALS

Imperial - L.S.D. S136-94

Mercury HF 305

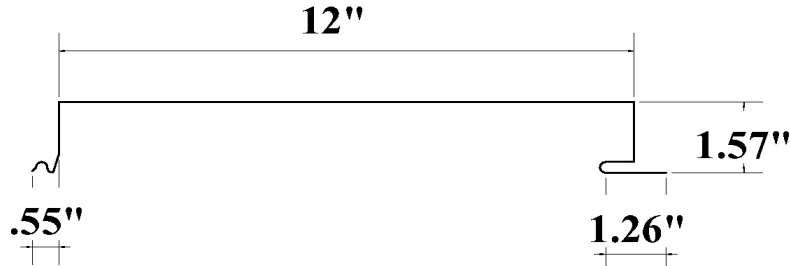

Properties for Mercury HF 305

(Per foot width)

Gauge Number	Base Steel Nominal Thickness Inches	Weight PSF	Overall Depth Inches	MID - SPAN					SUPPORT					Coeff. of Deflect. L / 180	Bearing Resist. 1" K / FT.	
				Section Modulus		Coeff. of Stress Csm	Moment of Inertia		Section Modulus		Coeff. of Stress Css	Moment of Inertia			EXT	INT
				Sm	In3		Im	In4	Ss	In3		Is	In4			
24	0.024	1.437	1.57	0.0773	1531	0.0762	0.0869	1721	0.1147	6646	0.23	0.43				
22	0.030	1.797	1.57	0.1097	2172	0.1066	0.1137	2251	0.1497	9297	0.34	0.72				
20	0.036	2.156	1.57	0.1464	2899	0.1464	0.1422	2816	0.1868	11975	0.47	1.07				

Specified Load Tables - psf

Span Ft.	ONE SPAN								TWO EQUAL SPANS								THREE EQUAL SPANS							
	0.024		0.030		0.036				0.024		0.030		0.036				0.024		0.030		0.036			
	A	B	A	B	A	B	A	B	A	B	A	B	A	B	A	B	A	B	A	B	A	B	A	B
2.0	153	*	227	*	313	*			143	*	227	*	313	*			143	*	227	*	313	*		
2.5	123	*	181	*	251	*			115	*	181	*	251	*			115	*	181	*	251	*		
3.0	102	*	151	*	209	*			96	*	151	*	209	*			96	*	151	*	209	*		
3.5	83	*	118	*	158	*			82	*	123	*	153	*			82	*	130	*	179	*		
4.0	64	*	91	*	121	*			72	*	94	*	117	*			72	*	113	*	147	*		
4.5	50	*	72	*	95	*			57	*	74	*	93	*			64	*	93	*	116	*		
6.0	28	*	40	*	54	*			32	*	42	*	52	*			40	*	52	*	65	*		
6.5	24	24	34	34	46	44			27	*	36	*	44	*			34	*	44	*	56	*		
7.0	21	19	30	27	39	35			23	*	31	*	38	*			29	*	38	*	48	*		
7.5	18	16	26	22	34	28			20	*	27	*	33	*			25	*	33	*	42	*		
8.0	16	13	23	18	30	23			18	*	23	*	29	*			22	*	29	*	37	*		
8.5	14	11	20	15	27	19			16	*	21	*	26	*			20	20	26	*	32	*		

Mercury HF 305 Load Table Notes

- Column 'A' - Loads based on stress. Column 'B' - Loads based on L / 180 deflection. (*) denotes stress governs.
- Table lists lower value of bending or bearing resistance. *Italic* denotes web crippling governs.
- For deflection loads other than L / 180 multiply column 'B' by the following factors:

<u>DEFLECTION</u>	<u>MULTIPLIER</u>
L / 240	0.75
L / 360	0.5
- Load tables based on use of A653 Structural Quality Steel Sheet Grade 33 (maximum stress 29.7 Ksi).

MERCURY METALS

Metric - L.S.D. S136-94

Mercury HF 305

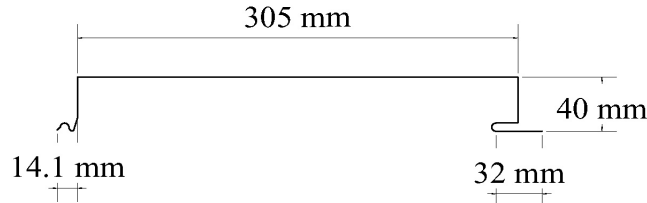

Properties for Mercury HF 305

(Per meter width)

Gauge Number	Base Steel Nominal Thickness mm	Weight Kpa	Overall Depth mm	MID - SPAN						SUPPORT						Coeff. of Deflect. L/180	Bearing Resist. for 25 mm	
				Section Modulus		Coeff. of Stress Csm	Moment of Inertia		Section Modulus		Coeff. of Stress Css	Moment of Inertia		L/180	kN / M			
				Sm	mm ³		Im	mm ⁴	Ss	mm ³		Is	mm ⁴		EXT		INT	
				x10 ³		x10 ³		x10 ³		x10 ³								
24	0.61	0.0688	40	4.155	6.8807	106.8	4.671	7.7352	156.6	9.2489	3.28	6.34						
22	0.76	0.0860	40	5.897	9.7654	145.5	6.112	10.1215	204.4	12.6065	4.93	10.5						
20	0.91	0.1032	40	7.871	13.02344	187.5	7.650	12.6684	255.1	16.2429	6.86	15.7						

Specified Load Tables - Kpa (Kn/m²)

Span M.	ONE SPAN								TWO EQUAL SPANS								THREE EQUAL SPANS							
	0.61		0.76		0.91				0.61		0.76		0.91				0.61		0.76		0.91			
	A	B	A	B	A	B	A	B	A	B	A	B	A	B	A	B	A	B	A	B	A	B	A	B
0.6	7.3	*	11	*	15	*			7.0	*	11	*	15	*			7.0	*	11	*	15	*		
0.8	5.5	*	8.2	*	11	*			5.3	*	8.2	*	11	*			5.3	*	8.2	*	11	*		
1.0	4.4	*	6.5	*	8.7	*			4.2	*	6.6	*	8.4	*			4.2	*	6.6	*	9.1	*		
1.2	3.2	*	4.5	*	6.0	*			3.5	*	4.7	*	5.9	*			3.5	*	5.5	*	7.3	*		
1.4	2.3	*	3.3	*	4.4	*			2.6	*	3.4	*	4.3	*			3.0	*	4.3	*	5.4	*		
1.6	1.8	*	2.5	*	3.4	*			2.0	*	2.6	*	3.3	*			2.5	*	3.3	*	4.1	*		
1.8	1.4	*	2.0	*	2.7	*			1.6	*	2.1	*	2.6	*			2.0	*	2.6	*	3.3	*		
2.0	1.1	*	1.6	1.6	2.2	2.0			1.3	*	1.7	*	2.1	*			1.6	*	2.1	*	2.6	*		
2.2	0.9	0.9	1.3	1.2	1.8	1.5			1.1	*	1.4	*	1.7	*			1.3	*	1.7	*	2.2	*		
2.4	0.8	0.7	1.1	0.9	1.5	1.2			0.9	*	1.2	*	1.5	*			1.1	*	1.5	*	1.8	*		
2.6	0.7	0.5	1.0	0.7	1.3	0.9			0.8	*	1.0	*	1.2	*			1.0	1.0	1.2	*	1.6	*		
2.8	0.6	0.4	0.8	0.6	1.1	0.7			0.7	*	0.9	*	1.1	*			0.8	0.8	1.1	1.1	1.3	*		

Mercury HF 305 Load Table Notes

- Column 'A' - Loads based on stress. Column 'B' - Loads based on L / 180 deflection. (*) denotes stress governs.
- Table lists lower value of bending or bearing resistance. *Italic* denotes web crippling governs.
- For deflection loads other than L / 180 multiply column 'B' by the following factors:

<u>DEFLECTION</u>	<u>MULTIPLIER</u>
L / 240	0.75
L / 360	0.5
- Load tables based on use of A653M Structural Quality Steel Sheet Grade 230 (maximum stress 207 Mpa).

MERCURY METALS

Imperial - L.S.D. S136-94

Mercury HF 305 R

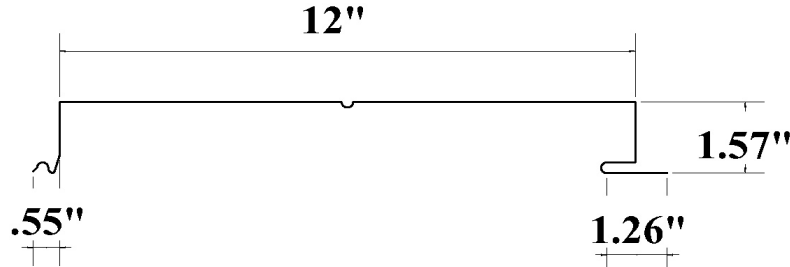

Properties for Mercury HF 305 R

(Per foot width)

Gauge Number	Base Steel Nominal Thickness	Weight	Overall Depth	MID - SPAN					SUPPORT					Coeff. of Deflect.	Bearing Resist. 1"	
				Section Modulus		Coeff. of Stress	Moment of Inertia		Section Modulus		Coeff. of Stress	Moment of Inertia			EXT	INT
	Inches	PSF	Inches	Sm	In3	Csm	Im	In4	Ss	In3	Css	Is	In4	L / 180		
24	0.024	1.437	1.57	0.0773		1531	0.0762		0.0869		1721	0.1147		6646	0.23	0.43
22	0.030	1.797	1.57	0.1097		2172	0.1066		0.1137		2251	0.1497		9297	0.34	0.72
20	0.036	2.156	1.57	0.1464		2899	0.1464		0.1422		2816	0.1868		11975	0.47	1.07

Specified Load Tables - psf

Span Ft.	ONE SPAN								TWO EQUAL SPANS								THREE EQUAL SPANS							
	0.024		0.030		0.036				0.024		0.030		0.036				0.024		0.030		0.036			
	A	B	A	B	A	B	A	B	A	B	A	B	A	B	A	B	A	B	A	B	A	B	A	B
2.0	153	*	227	*	313	*			143	*	227	*	313	*			143	*	227	*	313	*		
2.5	123	*	181	*	251	*			115	*	181	*	251	*			115	*	181	*	251	*		
3.0	102	*	151	*	209	*			96	*	151	*	209	*			96	*	151	*	209	*		
3.5	83	*	118	*	158	*			82	*	123	*	153	*			82	*	130	*	179	*		
4.0	64	*	91	*	121	*			72	*	94	*	117	*			72	*	113	*	147	*		
4.5	50	*	72	*	95	*			57	*	74	*	93	*			64	*	93	*	116	*		
6.0	28	*	40	*	54	*			32	*	42	*	52	*			40	*	52	*	65	*		
6.5	24	24	34	34	46	44			27	*	36	*	44	*			34	*	44	*	56	*		
7.0	21	19	30	27	39	35			23	*	31	*	38	*			29	*	38	*	48	*		
7.5	18	16	26	22	34	28			20	*	27	*	33	*			25	*	33	*	42	*		
8.0	16	13	23	18	30	23			18	*	23	*	29	*			22	*	29	*	37	*		
8.5	14	11	20	15	27	19			16	*	21	*	26	*			20	20	26	*	32	*		

Mercury HF 305 R Load Table Notes

- 1) Column 'A' - Loads based on stress. Column 'B' - Loads based on L / 180 deflection. (*) denotes stress governs.
- 2) Table lists lower value of bending or bearing resistance. *Italic* denotes web crippling governs.
- 3) For deflection loads other than L / 180 multiply column 'B' by the following factors:

<u>DEFLECTION</u>	<u>MULTIPLIER</u>
L / 240	0.75
L / 360	0.5
- 4) Load tables based on use of A653 Structural Quality Steel Sheet Grade 33 (maximum stress 29.7 Ksi).

MERCURY METALS

Metric - L.S.D. S136-94

Mercury HF 305 R

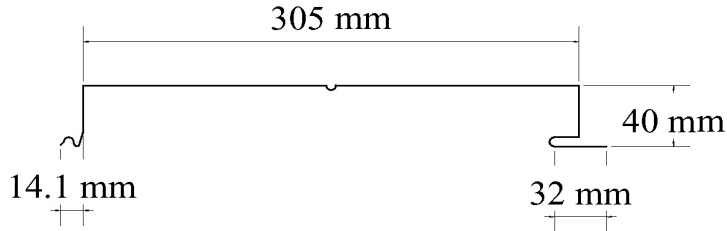

Properties for Mercury HF 305 R

(Per meter width)

Gauge Number	Base Steel Nominal Thickness	Weight	Overall Depth	MID - SPAN				SUPPORT				Coeff. of Deflect.	Bearing Resist.			
				Section Modulus	Coeff. of Stress	Moment of Inertia		Section Modulus	Coeff. of Stress	Moment of Inertia			for 25 mm			
	mm	Kpa	mm	Sm	mm ³	Csm	Im	mm ⁴	Ss	mm ³	Css	Is	mm ⁴	L/180	kN / M	EXT
24	0.61	0.0688	40	4.155	6.8807	106.8	4.671	7.7352	156.6	9.2489	3.28	6.34				
22	0.76	0.0860	40	5.897	9.7654	145.5	6.112	10.1215	204.4	12.6065	4.93	10.5				
20	0.91	0.1032	40	7.871	13.02344	187.5	7.650	12.6684	255.1	16.2429	6.86	15.7				

Specified Load Tables - Kpa (Kn/m²)

Span M.	ONE SPAN								TWO EQUAL SPANS								THREE EQUAL SPANS							
	0.61		0.76		0.91				0.61		0.76		0.91				0.61		0.76		0.91			
	A	B	A	B	A	B	A	B	A	B	A	B	A	B	A	B	A	B	A	B	A	B	A	B
0.6	7.3	*	11	*	15	*			7.0	*	11	*	15	*			7.0	*	11	*	15	*		
0.8	5.5	*	8.2	*	11	*			5.3	*	8.2	*	11	*			5.3	*	8.2	*	11	*		
1.0	4.4	*	6.5	*	8.7	*			4.2	*	6.6	*	8.4	*			4.2	*	6.6	*	9.1	*		
1.2	3.2	*	4.5	*	6.0	*			3.5	*	4.7	*	5.9	*			3.5	*	5.5	*	7.3	*		
1.4	2.3	*	3.3	*	4.4	*			2.6	*	3.4	*	4.3	*			3.0	*	4.3	*	5.4	*		
1.6	1.8	*	2.5	*	3.4	*			2.0	*	2.6	*	3.3	*			2.5	*	3.3	*	4.1	*		
1.8	1.4	*	2.0	*	2.7	*			1.6	*	2.1	*	2.6	*			2.0	*	2.6	*	3.3	*		
2.0	1.1	*	1.6	1.6	2.2	2.0			1.3	*	1.7	*	2.1	*			1.6	*	2.1	*	2.6	*		
2.2	0.9	0.9	1.3	1.2	1.8	1.5			1.1	*	1.4	*	1.7	*			1.3	*	1.7	*	2.2	*		
2.4	0.8	0.7	1.1	0.9	1.5	1.2			0.9	*	1.2	*	1.5	*			1.1	*	1.5	*	1.8	*		
2.6	0.7	0.5	1.0	0.7	1.3	0.9			0.8	*	1.0	*	1.2	*			1.0	1.0	1.2	*	1.6	*		
2.8	0.6	0.4	0.8	0.6	1.1	0.7			0.7	*	0.9	*	1.1	*			0.8	0.8	1.1	1.1	1.3	*		

Mercury HF 305 R Load Table Notes

- Column 'A' - Loads based on stress. Column 'B' - Loads based on L / 180 deflection. (*) denotes stress governs.
- Table lists lower value of bending or bearing resistance. *Italic* denotes web crippling governs.
- For deflection loads other than L / 180 multiply column 'B' by the following factors:

<u>DEFLECTION</u>	<u>MULTIPLIER</u>
L / 240	0.75
L / 360	0.5
- Load tables based on use of A653M Structural Quality Steel Sheet Grade 230 (maximum stress 207 Mpa).

MERCURY METALS

Imperial - L.S.D. S136-94

Mercury CORRUGATED

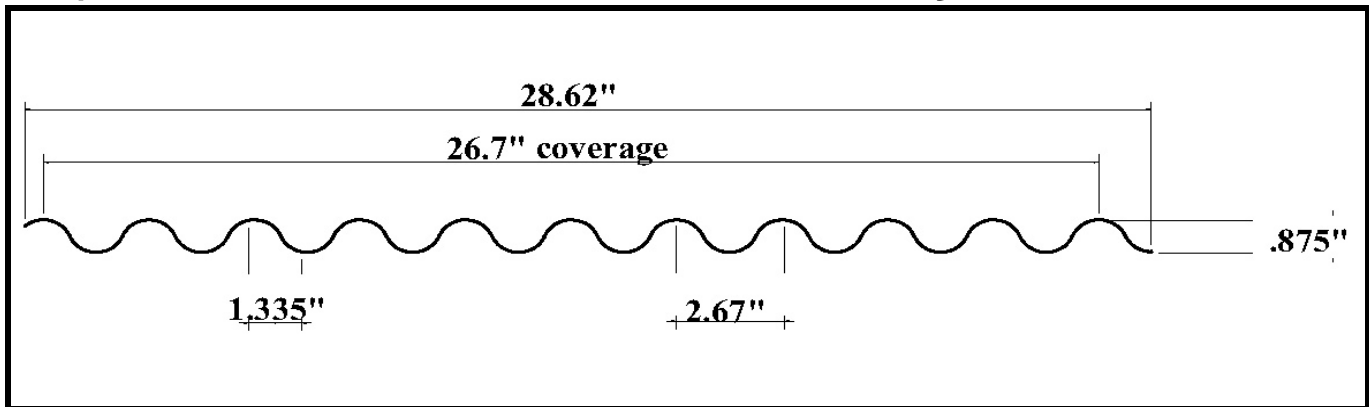

Properties for Mercury CORRUGATED

(Per foot width)

Gauge Number	Base Steel Nominal Thickness	Weight	Overall Depth	MID - SPAN					SUPPORT					Coeff. of Deflect.	Bearing Resist. 2"	
				Section Modulus		Coeff. of Stress	Moment of Inertia		Section Modulus		Coeff. of Stress	Moment of Inertia			L / 180	EXT
	Inches	PSF	Inches	Sm	In3	Csm	Im	In4	Ss	In3	Css	Is	In4	L / 180	EXT	INT
26	0.018	0.924	0.875	0.0570		1129	0.0254	0.0570		1129	0.0254		2219	0.36	0.36	
24	0.024	1.233	0.875	0.0770		1524	0.0332	0.0770		1524	0.0332		2894	0.87	0.95	
22	0.030	1.541	0.875	0.0941		1863	0.0406	0.0941		1863	0.0406		3538	1.35	1.81	
20	0.036	1.849	0.875	0.1104		2186	0.0476	0.1104		2186	0.0476		4151	1.92	2.96	

Specified Load Tables - psf

Span Ft.	ONE SPAN								TWO EQUAL SPANS								THREE EQUAL SPANS							
	0.018		0.024		0.030		0.036		0.018		0.024		0.030		0.036		0.018		0.024		0.030		0.036	
	A	B	A	B	A	B	A	B	A	B	A	B	A	B	A	B	A	B	A	B	A	B	A	B
1.5	320	*	452	*	552	*	648	*	160	*	422	*	552	*	648	*	160	*	422	*	690	*	810	*
2.0	188	*	254	*	311	*	364	*	120	*	254	*	311	*	364	*	120	*	317	*	388	*	455	*
2.5	120	*	163	*	199	*	233	*	96	*	163	*	199	*	233	*	96	*	203	*	248	*	291	*
3.0	84	82	113	107	138	131	162	154	80	*	113	*	138	*	162	*	80	*	141	*	173	*	202	*
3.5	61	52	83	67	101	83	119	97	61	*	83	*	101	*	119	*	69	*	104	*	127	*	149	*
4.0	47	35	64	45	78	55	91	65	47	*	64	*	78	*	91	*	59	*	79	*	97	*	114	*
4.5	37	24	50	32	61	39	72	46	37	*	50	*	61	*	72	*	46	46	63	60	77	73	90	86
5.0	30	18	41	23	50	28	58	33	30	*	41	*	50	*	58	*	38	34	51	44	62	53	73	63
5.5	25	13	34	17	41	21	48	25	25	*	34	*	41	*	48	*	31	25	42	33	51	40	60	47
6.0	21	10	28	13	35	16	40	19	21	*	28	*	35	*	40	*	26	19	35	25	43	31	51	36
6.5	18	8	24	11	29	13	34	15	18	*	24	*	29	*	34	*	22	15	30	20	37	24	43	29
7.0	15	6	21	8	25	10	30	12	15	*	21	20	25	25	30	29	19	12	26	16	32	19	37	23

Mercury CORRUGATED Load Table Notes

- 1) Column 'A' - Loads based on stress. Column 'B' - Loads based on L / 180 deflection. (*) denotes stress governs.
- 2) Table lists lower value of bending or bearing resistance. *Italic* denotes web crippling governs.
- 3) For deflection loads other than L / 180 multiply column 'B' by the following factors:

<u>DEFLECTION</u>	<u>MULTIPLIER</u>
L / 240	0.75
L / 360	0.5
- 4) Load tables based on use of A653 Structural Quality Steel Sheet Grade 33 (maximum stress 29.7 Ksi).

MERCURY METALS

Metric - L.S.D. S136-94

Mercury CORRUGATED

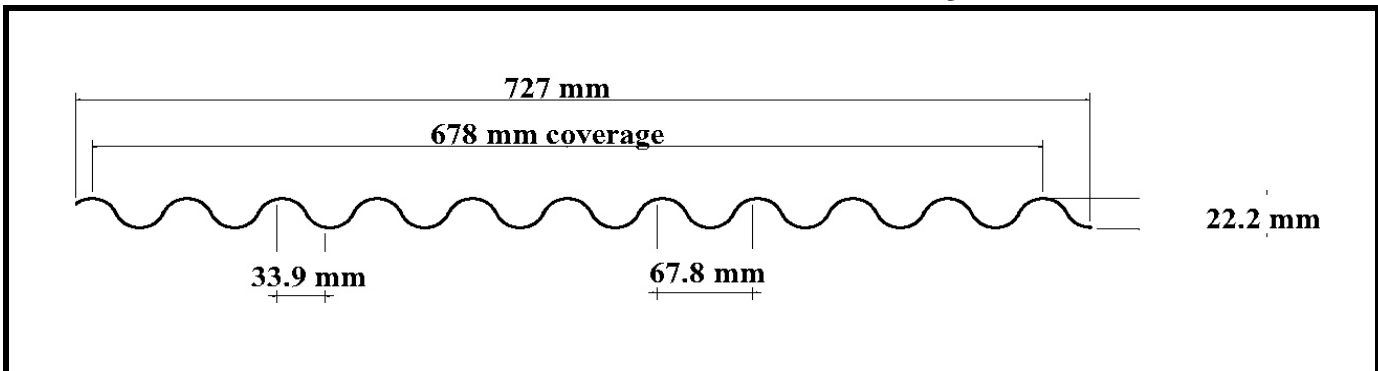

Properties for Mercury CORRUGATED

(Per meter width)

Gauge Number	Base Steel Nominal Thickness mm	Weight Kpa	Overall Depth mm	MID - SPAN					SUPPORT					Coeff. of Deflect. L/180	Bearing Resist. for 50 mm	
				Section Modulus Sm mm ³	Coeff. of Stress Csm	Moment of Inertia		Section Modulus Ss mm ³	Coeff. of Stress Css	Moment of Inertia		L/180	kN / M			
						mm ⁴	x10 ³			mm ⁴	x10 ³		EXT		INT	
				x10 ³		x10 ³	x10 ³	x10 ³								
26	0.46	0.0442	22.2	3.880	5.1142	34.7		3.880	5.1142	34.7		3.0093	5.31	5.31		
24	0.61	0.0590	22.2	4.139	6.8535	45.3		4.139	6.8535	45.3		3.9250	12.7	13.9		
22	0.76	0.0737	22.2	5.059	8.3775	55.4		5.059	8.3775	55.4		4.7984	19.7	26.5		
20	0.91	0.0885	22.2	5.936	9.8292	65.0		5.936	9.8292	65.0		5.6306	28.0	43.1		

Specified Load Tables - Kpa (Kn/m²)

Span M.	ONE SPAN								TWO EQUAL SPANS								THREE EQUAL SPANS							
	0.46		0.61		0.76		0.91		0.46		0.61		0.76		0.91		0.46		0.61		0.76		0.91	
	A	B	A	B	A	B	A	B	A	B	A	B	A	B	A	B	A	B	A	B	A	B	A	B
0.3	24	*	50.8	*	62.1	*	72.8	*	12	*	31	*	59	*	72.8	*	12	*	31	*	59	*	91.0	*
0.4	18	*	28.6	*	34.9	*	41.0	*	8.9	*	23	*	34.9	*	41.0	*	8.9	*	23	*	43.6	*	51.2	*
0.5	13.6	*	18.3	*	22.3	*	26.2	*	7.1	*	18.3	*	22.3	*	26.2	*	7.1	*	19	*	27.9	*	32.8	*
0.6	9.5	*	12.7	*	15.5	*	18.2	*	5.9	*	12.7	*	15.5	*	18.2	*	5.9	*	15	*	19.4	*	22.8	*
0.7	7.0	*	9.3	*	11.4	*	13.4	*	5.1	*	9.3	*	11.4	*	13.4	*	5.1	*	11.7	*	14.2	*	16.7	*
0.8	5.3	*	7.1	*	8.7	*	10.2	*	4.4	*	7.1	*	8.7	*	10.2	*	4.4	*	8.9	*	10.9	*	12.8	*
0.9	4.2	4.1	5.6	5.4	6.9	6.6	8.1	7.7	3.9	*	5.6	*	6.9	*	8.1	*	3.9	*	7.1	*	8.6	*	10.1	*
1.0	3.4	3.0	4.6	3.9	5.6	4.8	6.6	5.6	3.4	*	4.6	*	5.6	*	6.6	*	3.5	*	5.7	*	7.0	*	8.2	*
1.2	2.4	1.7	3.2	2.3	3.9	2.8	4.6	3.3	2.4	*	3.2	*	3.9	*	4.6	*	3.0	*	4.0	*	4.8	*	5.7	*
1.4	1.7	1.1	2.3	1.4	2.8	1.7	3.3	2.1	1.7	*	2.3	*	2.8	*	3.3	*	2.2	2.1	2.9	2.7	3.6	3.3	4.2	3.9
1.6	1.3	0.7	1.8	1.0	2.2	1.2	2.6	1.4	1.3	*	1.8	*	2.2	*	2.6	*	1.7	1.4	2.2	1.8	2.7	2.2	3.2	2.6
1.8	1.1	0.5	1.4	0.7	1.7	0.8	2.0	1.0	1.1	*	1.4	*	1.7	*	2.0	*	1.3	1.0	1.8	1.3	2.2	1.6	2.5	1.8

Mercury CORRUGATED Load Table Notes

- Column 'A' - Loads based on stress. Column 'B' - Loads based on L / 180 deflection. (*) denotes stress governs.
- Table lists lower value of bending or bearing resistance. *Italic* denotes web crippling governs.
- For deflection loads other than L / 180 multiply column 'B' by the following factors:

<u>DEFLECTION</u>	<u>MULTIPLIER</u>
L / 240	0.75
L / 360	0.5
- Load tables based on use of A653M Structural Quality Steel Sheet Grade 230 (maximum stress 207 Mpa).